

Laser Distance Sensor PGL-050W3/180W3 Technical Reference Manual

| | | | | | | |
|----------------|---|------------------|-------------|-------------|---|------------|
| △× | Correction of errors, etc., full review | | | 2019.8.21 | Iguchi | PR-6940 |
| Symbol | Amended reason | | | Date | Corrector | Amended No |
| Approved by | Checked by | Drawn by | Designed by | Title | PGL-050W3/180W3 Technical Reference Manual | |
| <i>M. Hino</i> | <i>M. Hino</i> | <i>T. Iguchi</i> | Yamaguchi | Drawing No. | | |

Table of Contents

| | |
|---|-----------|
| 1. Introduction | 5 |
| 1.1 Product identification..... | 6 |
| 1.2 Components..... | 6 |
| 1.3 Validity | 6 |
| 2. Technical data | 7 |
| 2.1 Specifications..... | 7 |
| 2.2 Physical dimensions..... | 8 |
| 2.3 Measuring accuracy definition | 8 |
| 3. Electrical components | 9 |
| 3.1 Power supply | 9 |
| 3.1.1 Specifications & Wiring..... | 9 |
| 3.1.2 Shielding | 9 |
| 3.2 Reset push button | 10 |
| 3.3 Status LED..... | 10 |
| 3.4 Digital output | 10 |
| 3.4.1 Specifications | 11 |
| 3.4.2 Wiring..... | 11 |
| 3.5 Digital input | 12 |
| 3.6 RS-232 interface..... | 12 |
| 3.6.1 Specifications | 12 |
| 3.6.2 Wiring..... | 12 |
| 3.7 RS-422 / RS-485 interface | 13 |
| 3.7.1 Specifications | 13 |
| 3.7.2 Wiring RS-422..... | 13 |
| 3.7.3 Wiring RS-485..... | 14 |
| 3.8 SSI interface..... | 15 |
| 3.8.1 Specifications | 15 |
| 3.8.2 Timing | 15 |
| 3.8.3 Wiring..... | 16 |
| 3.9 USB interface | 16 |
| 3.9.1 Specifications & Wiring..... | 17 |
| 3.9.2 Installation..... | 17 |
| 4. Configuration | 18 |
| 4.1 Configuration process | 18 |
| 4.1.1 Connection..... | 18 |
| 4.1.2 Configuration types | 19 |
| 4.2 Operation modes | 19 |
| 4.2.1 Controlled mode | 20 |
| 4.2.2 Stand-alone mode..... | 20 |
| 4.2.3 Error behavior..... | 21 |
| 4.3 Measuring characteristic | 22 |
| 4.4 Data output | 22 |
| 4.4.1 User output format / protocol | 23 |

| | | | | |
|-------|---|----------------|-----------|--------|
| Title | PGL-050W3/180W3 Technical Reference Manual | Drawing No. | C-41-2607 | 2 / 45 |
|-------|---|----------------|-----------|--------|



| | | |
|-----------|--|-----------|
| 4.4.2 | User gain / offset | 23 |
| 4.4.3 | Output filter (Distance / error)..... | 24 |
| 4.5 | Factory settings..... | 25 |
| 5. | Operation..... | 25 |
| 5.1 | Measurement overview | 25 |
| 5.2 | Installation | 26 |
| 5.2.1 | Connection of the device | 26 |
| 5.2.2 | Mounting of the device..... | 26 |
| 5.2.3 | Mounting of reflective plate..... | 26 |
| 5.2.4 | Alignment of the laser beam | 26 |
| 5.3 | Measuring performance influence | 27 |
| 5.4 | Prevention of erroneous measurements..... | 27 |
| 5.4.1 | Rough surfaces..... | 27 |
| 5.4.2 | Transparent surfaces..... | 27 |
| 5.4.3 | Wet, smooth or high-gloss surfaces..... | 27 |
| 5.4.4 | Inclined, round surfaces | 27 |
| 5.4.5 | Multiple reflections..... | 27 |
| 5.4.6 | Influence of sun light | 28 |
| 5.5 | Laser life time consideration | 28 |
| 6. | Command set | 28 |
| 6.1 | General | 28 |
| 6.1.1 | Command termination..... | 28 |
| 6.1.2 | Device identification N | 28 |
| 6.1.3 | Parameter separator..... | 28 |
| 6.1.4 | Set/Get commands | 28 |
| 6.1.5 | Startup sequence | 28 |
| 6.2 | Operation commands | 29 |
| 6.2.1 | Stop / Clear command (sNc) | 29 |
| 6.2.2 | Distance measurement (sNg) | 29 |
| 6.2.3 | Single sensor tracking (sNh) | 29 |
| 6.2.4 | Single sensor tracking with timer (sNh)..... | 30 |
| 6.2.5 | Tracking with buffering – Start (sNf) | 30 |
| 6.2.6 | Read out – Tracking with buffering (sNq) | 30 |
| 6.2.7 | Signal measurement (sNm)..... | 31 |
| 6.2.8 | Temperature measurement (sNt)..... | 31 |
| 6.2.9 | Read/Clear error stack (sNre, sNce) | 31 |
| 6.2.10 | Laser on (sNo) | 31 |
| 6.3 | Configuration commands..... | 32 |
| 6.3.1 | Set communication settings (sNbr)..... | 32 |
| 6.3.2 | Set device ID (sNid) | 32 |
| 6.3.3 | Set/Get digital output type (sNot)..... | 32 |
| 6.3.4 | Set/Get digital output hysteresis (sN1, sN2) | 33 |
| 6.3.5 | Set/Get digital input function (sNDI1) | 33 |
| 6.3.6 | Get digital input (sNRI)..... | 34 |
| 6.3.7 | Set/Get configuration of RS-422/SSI..... | 34 |
| 6.3.8 | Set/Get error value of SSI output..... | 35 |

| | | | | |
|-------|---|----------------|------------------|--------|
| Title | PGL-050W3/180W3 Technical Reference Manual | Drawing No. | C-41-2607 | 3 / 45 |
|-------|---|----------------|------------------|--------|



| | | |
|-----------|--|-----------|
| 6.3.9 | Set/Get measuring characteristic (sNmc) | 35 |
| 6.3.10 | Set/Get measurement filter configuration (sNfi)..... | 35 |
| 6.3.11 | Set auto start configuration (sNA)..... | 36 |
| 6.3.12 | Set configuration parameters to factory default (sNd)..... | 36 |
| 6.3.13 | Save configuration parameters (sNs)..... | 36 |
| 6.4 | Extended configuration commands | 37 |
| 6.4.1 | Set/Get user output format (sNuo)..... | 37 |
| 6.4.2 | Set/Get user distance offset (sNuof)..... | 37 |
| 6.4.3 | Set/Get user distance gain (sNuga)..... | 38 |
| 6.5 | Information commands | 38 |
| 6.5.1 | Get software version (sNsv)..... | 38 |
| 6.5.2 | Get serial number (sNsn) | 38 |
| 6.5.3 | Get device type (sNdt, dt)..... | 39 |
| 6.5.4 | Get device generation and type (dg)..... | 39 |
| 6.6 | Error codes..... | 40 |
| 7. | Safety instructions..... | 41 |
| 7.1 | Use of the instrument | 41 |
| 7.2 | Limits to use..... | 41 |
| 7.3 | Areas of responsibility..... | 42 |
| 7.4 | Hazards in use..... | 42 |
| 7.5 | Laser classification..... | 43 |
| 7.6 | Electromagnetic compatibility (EMC)..... | 43 |
| 7.7 | Producer standards | 43 |
| 7.8 | Disposal | 43 |
| 7.9 | Labeling..... | 44 |
| 7.10 | Laser Specification | 44 |
| 7.11 | Maintenance | 44 |
| 7.12 | Service..... | 45 |
| 8. | Glossary | 45 |

| | | | | |
|-------|---|----------------|-----------|--------|
| Title | PGL-050W3/180W3 Technical Reference Manual | Drawing No. | C-41-2607 | 4 / 45 |
|-------|---|----------------|-----------|--------|



1. Introduction

The PGL Series laser distance sensors are powerful distance-measuring instruments for integration into industrial applications. They allow accurate and contactless distance measurement over a wide range using the laser beam reflection on a measuring surface / target (see the illustration in figure Figure1-1).

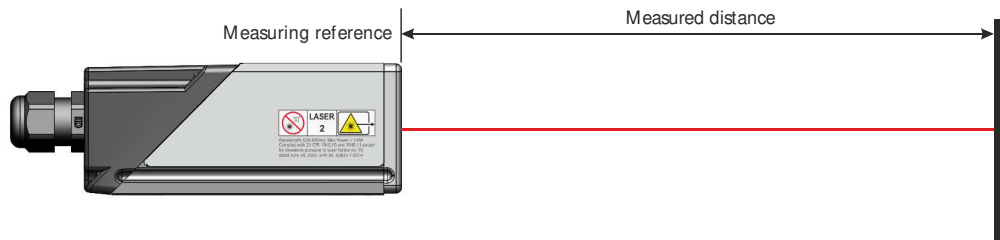

Figure 1-1: Standard application for measuring distances

Key features:

- Measurement range PGL-050W3: 0.05~50m PGL-180W3:0.05~180m
- Measuring accuracy up to ± 3.0 mm
- High measurement speed (up to 100 Hz output rate)
- Several serial interfaces (RS-232, RS-422/485, SSI and USB)
- Connection of up to 100 sensors on a single RS-422 line
- Wide range of power supply (12~30 VDC)
- One programmable digital input (DI1)
- Two programmable digital outputs (DO1 and DO2)
- Digital output for error signalization (DOE)
- Selectable digital output type (NPN, PNP, Push-Pull)
- 4 LED's for status signaling
- ASCII protocol to control external displays
- Screw terminal for easy connection of the PGL-Series sensors
- IP65 (protected against ingress of dust and water)
- Wide range of operating temperature (down to -40°C and up to $+60^{\circ}\text{C}$, for devices with extended temperature range)
- Visible red laser, laser class II (<0.95 mW)
- Configuration software available from Hokuyo website (www.hokuyo-aut.jp)



Use of controls, adjustments or performance of procedures other than those specified in this Technical Reference Manual may result in hazardous radiation exposure.



For easy starting with the PGL-Series sensors you can use our free configuration software "Laser Sensor Utility" from our website.

1.1 Product identification

This sensor products are identified by the label on the top of the sensors. The identification on the label shows the main properties of each sensor such as product series, range, interface, and number of I/O.

<Device Type>

PGL - □□□ W 3

- PGL ... series
- ... Specification distance
050:50m ,180:180m
- W ... Interface
(RS-232C/RS422)
- 3 ... I/O 3:3

Available sensor products

- PGL-050W3
- PGL-180W3

For detailed specifications of every sensor product, see 2.1 Specifications

1.2 Components

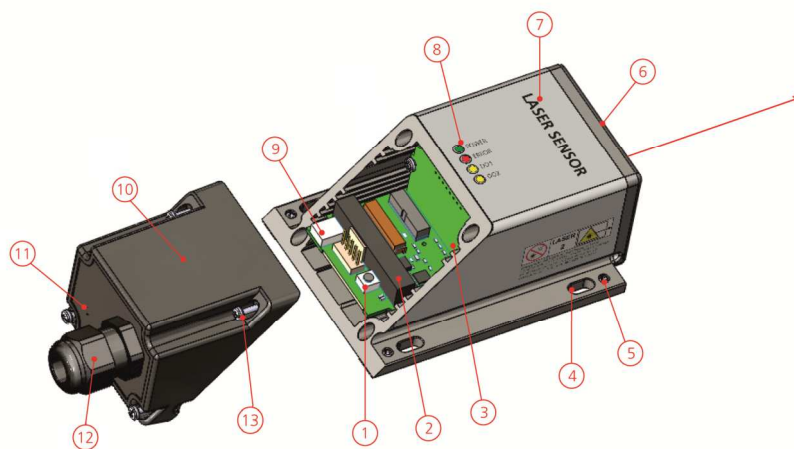

Figure.1-2 Product configuration

| | |
|--|---|
| ① Reset push button | ⑧ Status LED's (Power, error, digital outputs) |
| ② Screw terminal block & plug. For conductor cross section 0.14~1.5 mm ² . (Power supply, digital input / output, analog output, RS-232 and RS-422 / RS-485 / SSI) | ⑨ USB 2.0 Mini-B |
| ③ Shield tab for an adequate receptacle | ⑩ Terminal cover |
| ④ Slot hole for installation and alignment (M4 or M3 screws) | ⑪ Valve diaphragm |
| ⑤ Hexagon socket set screw for sensor alignment | ⑫ Cable gland M16 x 1.5 mm (Cable diameter: 5~10 mm, tool size: 20 mm) |
| ⑥ Sensor front (Laser beam output and receiver lens) | ⑬ Screws, Philips Slotted Combo (Philips size 1, slot size 2) |
| ⑦ Product label (for more details, see in chapter 7.9) | |



Generally the sensor with removed back cover is a sensitive device. Take precaution against electrostatic discharge (ESD). Only handle the device properly grounded and with care. No warranty will be granted on improper handling and / or ESD caused problems.

1.3 Validity

This manual is valid for PGL-Series sensors with the following software version:

Interface software version: V1.06 or later

Module software version: V3.3 or later

To get the software version use the command described in 6.5.1 Get software version (sNsv).

| | | | | |
|-------|---|-------------|-----------|--------|
| Title | PGL-050W3/180W3 Technical Reference Manual | Drawing No. | C-41-2607 | 6 / 45 |
|-------|---|-------------|-----------|--------|



2. Technical data

2.1 Specifications

| Model | PGL-050W3 | PGL-180W3 |
|--|--|-------------------------------|
| Typical measuring accuracy 1) 2) @ 2 σ (95.4% confidence level) @ 1 σ (68.3% confidence level) | ± 3.0 mm ± 1.5 mm | ± 3.0 mm ± 1.5 mm |
| Typical repeatability 1) 2) @ 2 σ (95.4% confidence level) @ 1 σ (68.3% confidence level) | ± 0.7 mm ± 0.35 mm | ± 0.7 mm ± 0.35 mm |
| Measuring range on natural surfaces 3) | 0.05~50 m | 0.05~100 m |
| Measuring range on orange (reflective) foil | — | 0.5~180 m |
| Measuring reference | From front edge (see 2.2 Physical dimensions) | |
| Smallest unit displayed | 0.1 mm | |
| Max. measuring rate 1) | 100 Hz | |
| Output rate for tracking measurement 1) | up to 100Hz | |
| Typical time for a measurement 1) Single measurement Tracking | 0.05~4 s 0.004~4 s | |
| Light source | Laser diode 620-690 nm (red, typical 650 nm) IEC/EN 60825-1:2014; Class 2 FDA 21 CFR 1040.10 and Laser Notice 50 Beam divergence: 0.16 x 0.6 mrad, Pulse duration: 0.2~0.8 x 10 ⁻⁹ s, Maximum radiant power: 1 mW | |
| Typical laser life time | 50'000 h @ 20°C (see 5.5 Laser life time consideration) | |
| Typical diameters (elliptic) of laser spot on target at a defined distance 4) | @ 5 m : 4 mm / 2 mm @ 10 m : 7 mm / 3 mm @ 30 m : 17 mm / 9 mm @ 50 m : 28 mm / 13 mm @ 100 m : 55 mm / 30 mm | |
| Electromagnetic compatibility (EMC) | IEC/EN 61000-6-4 / 61000-6-3 IEC/EN 61000-6-2 / 61000-6-1 | |
| Power supply Voltage range Current consumption (@ 24 VDC) 5) Current consumption (@ 12 VDC) 5) | 12~30 VDC 0.15 A 0.2A | 12~30 VDC 0.5 A 0.8 A |
| Temperature range during operation 6) | -10~+50°C | |
| Temperature range during storage | -40~+70°C | |
| Degree of protection | IP65 IEC60529 (Protected against ingress of dust and water) | |
| Dimensions | 140×78×48 mm | |
| Weight | 350 g | |
| Material Main sensor body Sensor front & Standard exchangeable cover | Aluminum Alloy EN-AW 6060 (Anodized 20um) Mineral reinforced nylon resin 7) | |
| Standard integrated interfaces of sensor Digital output (programmable) Digital output (error status) Digital input (programmable) RS-232 RS-422 / RS-485 with ID 0..9 SSI USB | 2 1 1 1 1 1 1 1 | |

Title

PGL-050W3/180W3
Technical Reference Manual

Drawing
No.

C-41-2607

7/45



- 1)The accuracy and measurement speed depend on the configuration of the measurement characteristic, see 4.3 Measuring characteristic and environmental conditions, see 5.3 Measuring performance influence.
- 2)Confidence level description, see 2.3 Measuring accuracy definition according the ISO-recommendation ISO/R 1938-1:2015.
- 3)Performance on natural surfaces depends on target reflectivity, background light and atmospheric conditions (see also 5.3 Measuring performance influence).
- 4)The spot-size can vary depending on production lot.
- 5)The current consumption of the device is defined without connected analog and digital outputs (AO, DO1, DO2 and DOE). The current consumption of used analog and / or digital outputs has to be considered in addition.
- 6)In case of permanent measurement (continuous distance measurement) the max. temperature during operation may be reduced.
- 7)Material with high mechanical strength, excellent balance of stiffness/toughness, good high temperature performance and good chemical resistance

2.2 Physical dimensions

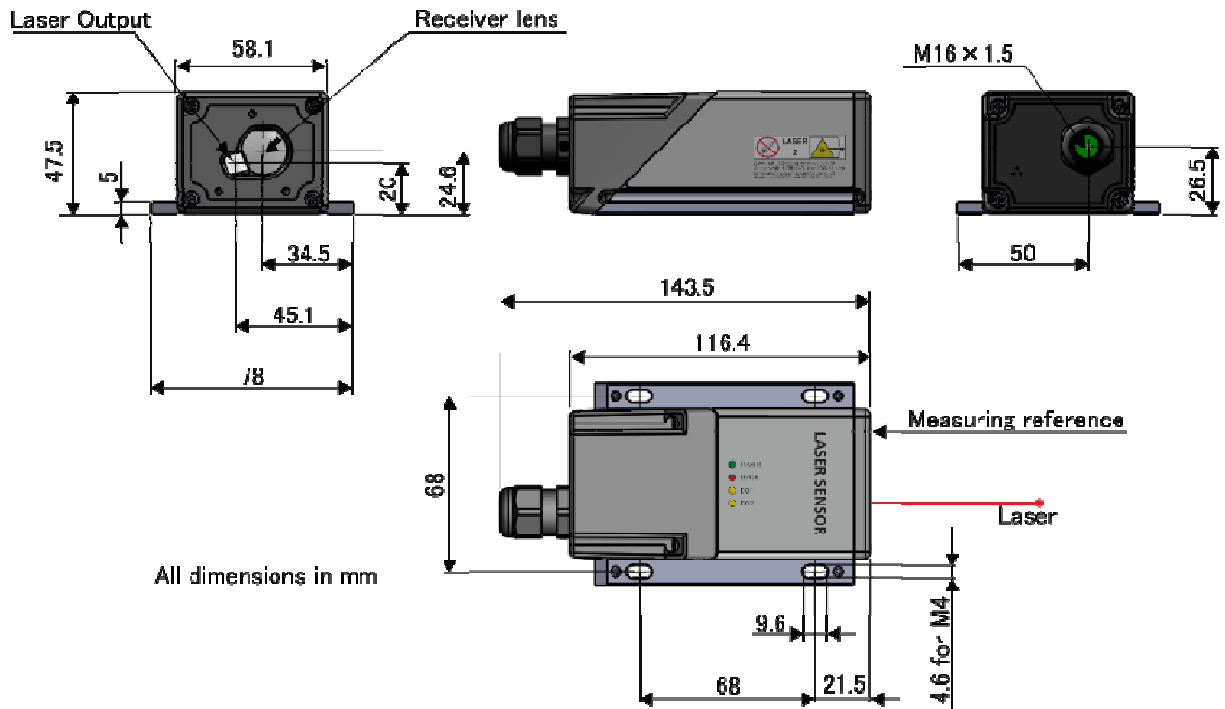

Figure 2-1: Physical dimensions of sensor

2.3 Measuring accuracy definition

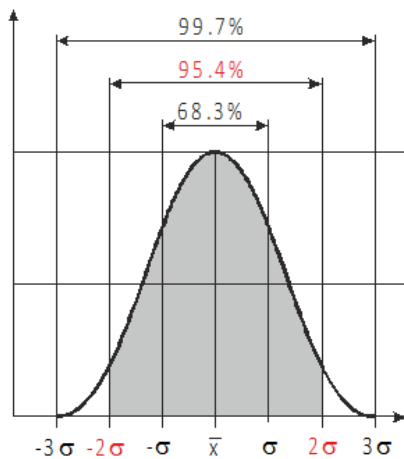

Figure 2-2: Measuring accuracy definition

The measuring accuracy corresponds to the ISO-recommendation ISO/R 1938-1:2015 with a statistical confidence level of 95.4% (i.e. \pm twice the standard deviation σ , see Figure 2-2 on the left). The typical measuring accuracy relates to average conditions for measuring. It is ± 1.0 mm for the Dxx-10-xxx and ± 3.0 mm for the Dxx-30-xxx valid in the tracking mode.

Maximum deviation may occur under unfavorable conditions such as bright sunlight or when measuring to poorly reflecting or very rough surfaces. Measuring accuracy may deteriorate by approximately ± 0.02 mm/m for distances above 30m.

PGL-Series sensors do not compensate changes of atmospheric environment. These changes can influence the accuracy if measuring long distances (>150 m) under conditions very different from 20°C, 60% relative humidity and 953 mbar air pressure. The influences of the atmospheric environment are described in H. Kahmen & W. Faig: "Surveying", (1988).

Title

PGL-050W3/180W3
Technical Reference Manual

Drawing
No.

C-41-2607

8/45



HOKUYO AUTOMATIC CO.,LTD.

3. Electrical components

The main electrical components of the PGL-Series laser distance sensors are described in the following chapter. The overview of the relevant components are shown in Figure.2-3.

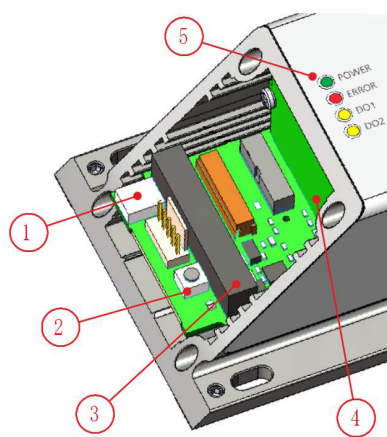

Figure2-3: Overview electrical components



Generally the sensor with removed back cover is a sensitive device. Take precaution against electrostatic discharge (ESD). Only handle the device properly grounded and with care. Nor warranty will be granted on improper handling and / or ESD caused problems.

3.1 Power supply

3.1.1 Specifications & Wiring

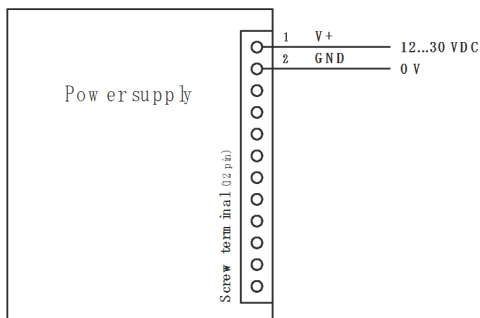

Figure 3-1: Connection of power supply (V+ and GND)

All the PGL-Series sensors are overvoltage and reverse voltage protected. But for proper operation of the sensors consider the power supply requirements and the corresponding specifications.

Specifications for power supply:

Voltage requirement: 12~30 VDC

Current requirement: Depends on sensor type
(for details see chapter 2.1)

The green status LED (POWER) indicates a powered and running device.



Only use high-quality power supply equipment and consider the voltage and current requirements of the this sensors. For trouble-free operation it's recommended to use a separate power supply for the sensors.

3.1.2 Shielding

Aluminum housing (Shield)

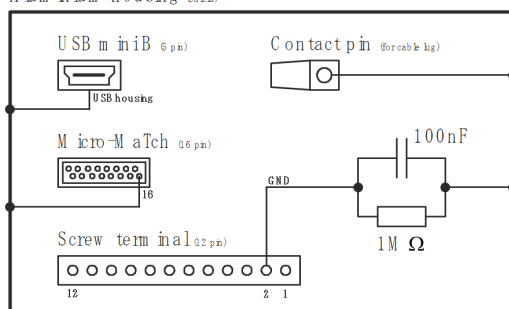

Figure 3-2: Shielding concept of the sensors

The shielding concept of the PGL-Series sensors is shown in figure Figure. The aluminum housing of the sensor corresponds to shield and is also connected to the housing of the USB interface, to the Micro-MaTch connector and the shield tab. The shield tab can be used to connect the shield of a cable to the sensor shield (use an adequate receptacle). The general GND of the device is connected to the shield / sensor housing by an R-C element (for details about the R-C element, see Figure 3-2.).

Title

PGL-050W3/180W3
Technical Reference Manual

Drawing
No.

C-41-2607

9/45





Use proper shielding concept to prevent the PGL-Series sensor and the control system from inexplicable interferences or other problems.

3.2 Reset push button

The reset procedure sets the sensor configuration back to factory default (see 4.5 Factory settings). This also may help if there is a problem with the sensor e.g. no communication over serial interfaces. The following steps show the reset procedure with the reset push button inside the PGL-Series sensors.

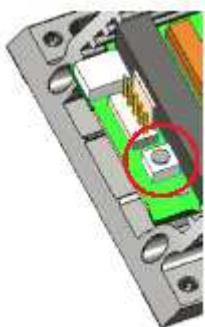

Reset procedure:

- 1) Switch off the power supply used for the device
- 2) Press the reset push button and keep it pressed
- 3) Switch on the power supply used for the device
- 4) Keep the reset push button pressed until all status LED's (POWER, ERROR, DO1, DO2) flash for a short time (about 0.5 seconds)
- 5) Release the reset push button
- 6) Switch off the power supply and wait 5 seconds
- 7) Switch on the power supply and wait until the green status LED (POWER) is on.
- 8) Reset procedure executed successfully

Figure 3-3: Reset push button

3.3 Status LED

The four status LED's (POWER, ERROR, DO1, DO2) on the top of the PGL-Series sensor shows the operating status of the sensor and the digital outputs (DO1, DO2). The possible LED status with the appropriate status description and some useful references are described in the table below.

| POWER | ERROR | DO1 | DO2 | Status of sensor – Description |
|-------|-------|-----|-----|---|
| ● | | | | The device is powered and ready for operation → Normal sensor operation. |
| ● | ● | | | The device is powered but an error occurred during the normal sensor operation. The error code is transmitted over the serial interfaces. For information about the error code number, see chapter 6.6. |
| ● | | ● | ● | The device is powered and running → Normal sensor operation. One and / or both digital output (DO1, DO2) can be ON or OFF depending on the configured switching levels (for more details see chapter 3.4 and 4). |
| ● | ● | ● | ● | Flash for about 0.5 seconds during reset procedure with the reset push button (see chapter 3.2) |
| | ● | ● | ● | The device is in error state. See the error code on the serial interface and contact HOKUYO if error persists after power cycle and reset. Normal case if power LED is off → Sensor supply voltage too low / high. For information about the error code number, see chapter 6.6. |

3.4 Digital output

The PGL-Series sensor contains two (or one) digital outputs (DO1 and DO2) for level monitoring and one digital output (DOE) for error signalization. These outputs can be configured as NPN, PNP or Push-Pull output type. The digital outputs are able to drive up to 150 mA and are specified for an output voltage of 30 VDC. The details about the output specifications and types are described in 3.4.1 Specifications.

| | | | | |
|-------|---|-------------|-----------|-------|
| Title | PGL-050W3/180W3 Technical Reference Manual | Drawing No. | C-41-2607 | 10/45 |
|-------|---|-------------|-----------|-------|



3.4.1 Specifications

| | | | |
|--|---|-----------------|-----------------------|
| | Properties / Possibilities | | |
| Output voltage LOW (active) NPN, Push-Pull | 0.2 V @ 10 mA (max.) 1.5 V @ 100 mA (max.) 2 V @ 150 mA (max.) | | |
| Output voltage HIGH (active) PNP, Push-Pull | (V+) - 0.2 V @ 10 mA (max.) (V+) - 1.5 V @ 100 mA (max.) (V+) - 2 V @ 150 mA (max.) | | |
| Output voltage OPEN (inactive, high impedance) NPN, PNP | 12~30 VDC (max.) | | |
| Output current | up to 150 mA | | |
| Output slew rate | max. 40 V/μs | | |
| Output types | Types | Output ON | Output OFF |
| | NPN | LOW (GND / 0 V) | OPEN (high impedance) |
| | PNP | HIGH (V+) | OPEN (high impedance) |
| | Push-Pull | HIGH (V+) | LOW (GND / 0 V) |
| Protections | Reverse polarity Over-voltage Current limited (max. 450 mA) Short circuit (thermal shutdown) | | |
| Cable length | < 30 m unshielded cable possible (indoor only) ≥ 30 m or outdoor use shielded cables only | | |

The typical connections for the configurable digital output types are shown in Figure 3-4. The load marked in the figure is a place holder for a specific load for example a relay or indicator light. If the digital output signal of the PGL-Series sensor is used as a digital input signal e.g. for a PLC, the push-pull output has to be used. But it's also possible to use the NPN or PNP output type with an additional pull-up / pull-down resistor.

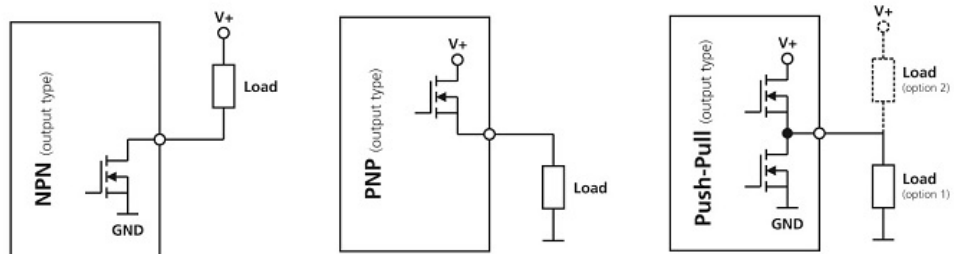

Figure 3-4: Digital output types (NPN, PNP, Push-Pull) with typical load connection

3.4.2 Wiring

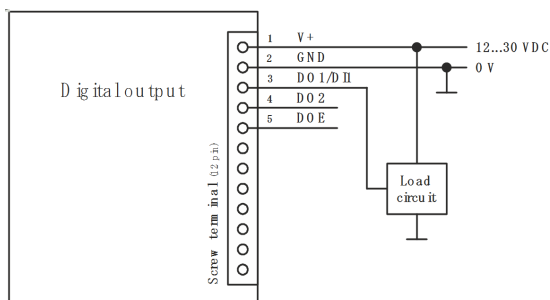

Figure 3-5: Connection for digital output (DO1, DO2, DOE)

The connection to use the digital outputs of the PGL-Series sensor is shown in Figure (example with DO1, analogous for DO2 and DOE outputs).

For detailed information about the load circuit, see the descriptions of the digital output types in chapter 3.4.1 and Figure 3-5.

Title

PGL-050W3/180W3
Technical Reference Manual

Drawing
No.

C-41-2607

11/45



3.5 Digital input

The digital output (DO1/DI1) can also be used as digital input. This digital input allows triggering or start / stop measurements by an external digital signal. There are different configuration possibilities available, for more details see the configuration command 6.3.8 Set/Get digital input function (sNDI1).

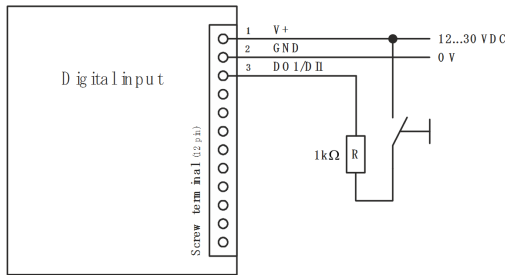

Specifications for digital input signals:

Low level: $U_{DI1} < 2 \text{ VDC}$

High level: $9 \text{ VDC} < U_{DI1} < 30 \text{ VDC}$

To protect the digital input / output against short circuit always use a $1 \text{ k}\Omega$ resistor before DO1/DI1 terminal.

The connection and wiring to use the digital input is shown in figure.

Figure 3-6: Connection of digital input for external triggering



Always check wiring of digital input / output (DO1/DI1) before doing the configuration of a digital input function.

3.6 RS-232 interface

The RS-232 digital serial interface is mainly used for the device configuration. It allows the connection with a host (e.g. PC) to do the configuration with a terminal program (e.g. HTerm, HyperTerminal or the Distance Sensor Utility software). The communication protocol is ASCII based, easy to understand and simple to use. For more details about the communication protocol and the available commands see 6 Command set. The factory settings of the RS-232 interface are specified in chapter 4.5 Factory settings.



Measurement rates faster than about 100 Hz are only possible if the baud rate is set to the maximum of 115'200 Baud. Lower baud rates reduce the measurement speed.

3.6.1 Specifications

The following specifications are in addition to the RS-232 standard specification. The standard specifications / guidelines are free available e.g. online.

| | Properties / Possibilities |
|-----------------------------|--|
| Voltage level | See RS-232 standard specifications / guidelines |
| Max. baud rate | 115'200 |
| Max. cable length (typical) | $\leq 15 \text{ m}$ (unshielded cable for indoor use only) |

3.6.2 Wiring

The connection of a PGL-Series sensor over the RS-232 interface with a host (e.g. PC or PLC) is shown in Figure 3-7. With the RS-232 interface only point-to-point communication is possible.

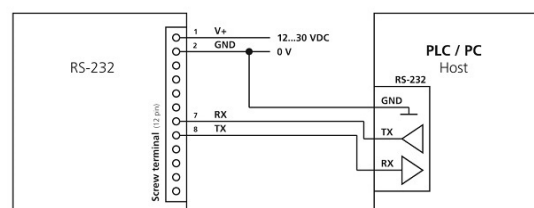

Figure 3-7: Connection of the RS-232 interface

| | | | | |
|-------|---|-------------|-----------|---------|
| Title | PGL-050W3/180W3 Technical Reference Manual | Drawing No. | C-41-2607 | 12 / 45 |
|-------|---|-------------|-----------|---------|





Never connect multiple PGL-Series devices on a single RS-232 line.

3.7 RS-422 / RS-485 interface

The RS-422 / RS-485 digital serial interface is made for industrial applications due to their robustness, max. Cable length and the possibility of connection multiple devices on the same line. For this interface a shielded cable with twisted pairs for the data signals have to be used (see 3.7.1 Specifications for further information).

The communication protocol is unchanged and identical with the protocol for the RS-232 interface. For more details about the communication protocol and the available commands see 6 Command set. The factory settings of the RS-422 / RS-485 interface are specified in chapter 4.5 Factory settings.

It's important that the host has the control of the whole communication and never initiates a new communication before terminating the previous one (always waiting for the answer of the PGL-Series sensor or timeout).



The RS-422 interface cannot be used simultaneous with the SSI interface.



For more than one device on a single line, never use commands with continuous answers (e.g. single sensor tracking). Only use tracking with buffering (see 6.2.5 Tracking with buffering-Start (sNf)).



Measurement rates faster than about 100 Hz are only possible if the baud rate is set to the maximum of 115'200 Baud. Lower baud rates reduce the measurement speed.

3.7.1 Specifications

The following specifications are in addition to the RS-422 / RS-485 standard specifications.

| | Properties / Possibilities |
|---|---|
| Voltage level | See RS-422 / RS-485 standard specifications / guidelines |
| Max. baud rate | 115'200 |
| Max. load for driver | $\geq 100 \Omega$ |
| Cable characteristics Cable type Characteristic impedance Z_0 (typical) | Use shielded twisted pair cables only (twisted pairs: T+/T- and R+/R-) 100~150 Ω (typical) |
| Termination resistor R_T | 100~150 Ω (typical), should be equal to cable impedance Z_0 |
| Cable length vs baud rate (typical) | ≤ 500 m \rightarrow $\leq 200'000$ Baud (all baud rates possible) ≤ 1000 m \rightarrow $\leq 100'000$ Baud |

3.7.2 Wiring RS-422

The connection of one or more PGL-Series sensor (up to 10) over the RS-422 interface with a host (e.g. PC or PLC) is shown in Figure 3-8. To use more than one PGL-Series sensor on a single RS-422 line the device ID of every device has to be configured with different ID's. Available and configurable ID's are form 0 to 99 (see 6.3.2 Set device ID (sNid)).

For proper operation use termination resistors R_T as shown in Figure 3-8. The termination resistor should be equal to the cable impedance Z_0 (typical 100~150 Ω).

| | | | | |
|-------|---|-------------|-----------|-------|
| Title | PGL-050W3/180W3 Technical Reference Manual | Drawing No. | C-41-2607 | 13/45 |
|-------|---|-------------|-----------|-------|



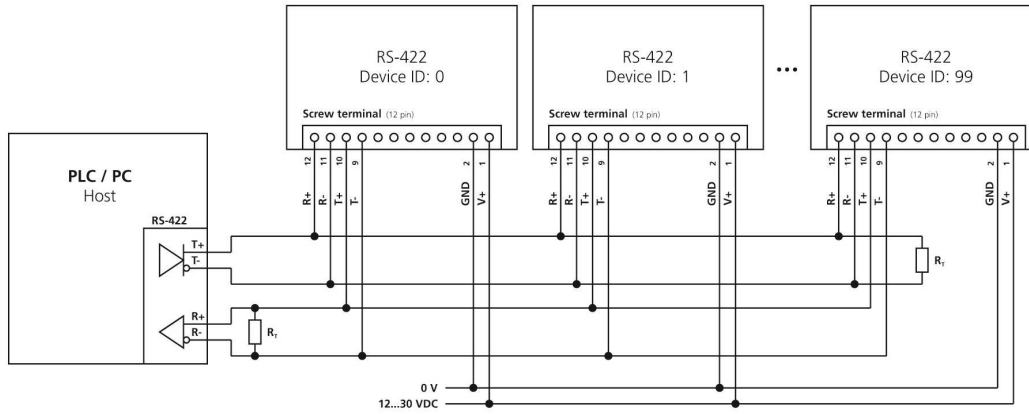

Figure 3-8: Connection of one or more RS-422 devices on one line, $R_T \rightarrow$ Termination resistors



If there are multiple devices on the same RS-422 line ensure that all devices have different device ID's.



Use shielded twisted pairs cables only. For details see 3.8.1 Specifications.

3.7.3 Wiring RS-485

The connection of one or more PGL-Series sensor (up to 10) over the RS-485 interface with a host (e.g. PC or PLC) is shown in Figure. To use more than one PGL-Series sensor on a single RS-485 line the device ID of every device has to be configured with different ID's. Available and configurable ID's are from 0 to 99 (see 6.3.2 Set device ID (sNid)).

For proper operation use termination resistors R_T as shown in Figure 3-9. The termination resistor should be equal to the cable impedance Z_0 (typical 100~150 Ω).

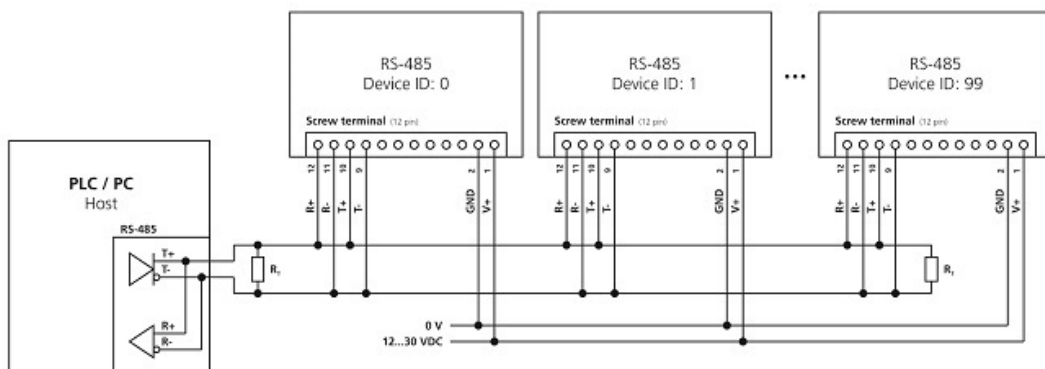

Figure 3-9: Connection of one or more RS-485 devices on one line, $R_T \rightarrow$ Termination resistors



If there are multiple devices on the same RS-485 line ensure that all devices have different device ID's.



Use shielded twisted pairs cables only. For details see 3.8.1 Specifications.

3.8 SSI interface

The SSI interface is also made for industrial applications due to their synchronous communication, the robustness (because of differential signals) and max. possible cable length. For this interface a shielded cable with twisted pairs for the data signals have to be used (see 3.8.1 Specifications for further information).

It's possible to configure the SSI interface with different data formats / sizes, data coding (Binary or gray) and some other options. For detailed information see the configuration command in chapter 6.3.10 Set/Get configuration of RS-422/SSI and 6.3.11 Set/Get error value of SSI output. The factory settings of the SSI interface are specified in chapter 4.5 Factory settings.



The SSI interface cannot be used simultaneous with the RS-422 / RS-485 interface.

3.8.1 Specifications

| | Properties / Possibilities | | | | | | | | | | | | |
|---|--|---------------|---|---------------|---------|---|--------------|---------|---|--------------|----------|---|--------------|
| Distance output values | 0~16777215 1/10 mm (max. 1.67 km) | | | | | | | | | | | | |
| Resolution | 0.1 mm | | | | | | | | | | | | |
| Data coding | Binary or gray, MSB first (configurable) | | | | | | | | | | | | |
| Data format / size Distance data State / Error data | 23 / 24-Bit (configurable) 0 / 1-Bit error state (configurable) 0 / 8-Bit error code (configurable) | | | | | | | | | | | | |
| Error value behavior | -2 / -1 / 0~16777215 (configurable) | | | | | | | | | | | | |
| Read out rate | ≤ 500 Hz | | | | | | | | | | | | |
| Clock frequency (Clock from master device) | 83 kHz to 1 MHz, depending on cable length | | | | | | | | | | | | |
| Pause time t_p (Time lag between two data packets) | > 1 ms | | | | | | | | | | | | |
| Monoflop time t_m | 25 μ s | | | | | | | | | | | | |
| Voltage level | See RS-422 / RS-485 guidelines (differential signals) | | | | | | | | | | | | |
| Cable characteristics | Use shielded twisted pair cables only (twisted pairs: T+/T- and R+/R-) | | | | | | | | | | | | |
| Cable length vs data rate (typical) | <table style="border: none;"> <tr> <td>≤ 100 m</td> <td>→</td> <td>≤ 1000 kBit/s</td> </tr> <tr> <td>≤ 200 m</td> <td>→</td> <td>≤ 600 kBit/s</td> </tr> <tr> <td>≤ 500 m</td> <td>→</td> <td>≤ 200 kBit/s</td> </tr> <tr> <td>≤ 1000 m</td> <td>→</td> <td>≤ 100 kBit/s</td> </tr> </table> | ≤ 100 m | → | ≤ 1000 kBit/s | ≤ 200 m | → | ≤ 600 kBit/s | ≤ 500 m | → | ≤ 200 kBit/s | ≤ 1000 m | → | ≤ 100 kBit/s |
| ≤ 100 m | → | ≤ 1000 kBit/s | | | | | | | | | | | |
| ≤ 200 m | → | ≤ 600 kBit/s | | | | | | | | | | | |
| ≤ 500 m | → | ≤ 200 kBit/s | | | | | | | | | | | |
| ≤ 1000 m | → | ≤ 100 kBit/s | | | | | | | | | | | |

3.8.2 Timing

The timing of the SSI interface is shown in Figure and described below the Figure 3-10.

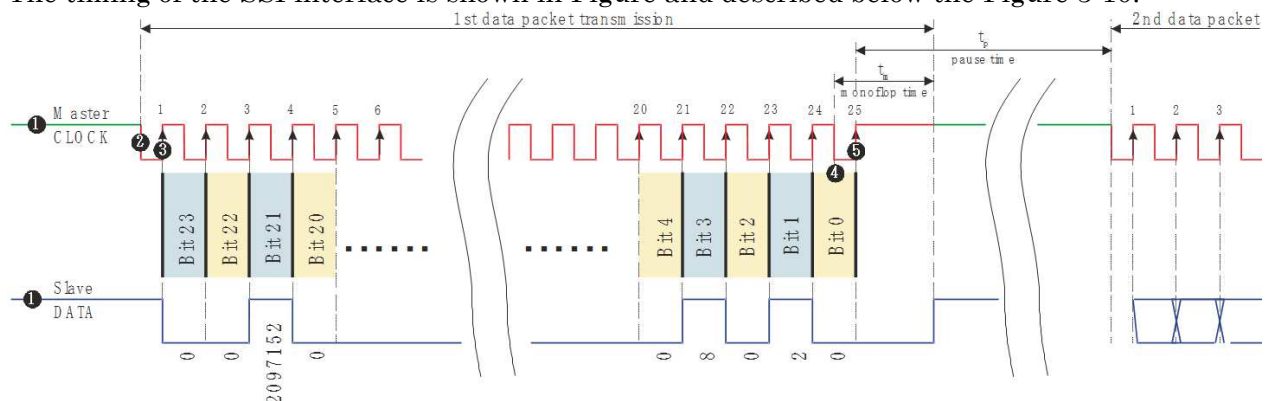

Figure 3-10: Timing diagram of SSI interface (t_m → Monoflop time, t_p → Pause time).

| | | | | |
|-------|---|-------------|-----------|-------|
| Title | PGL-050W3/180W3 Technical Reference Manual | Drawing No. | C-41-2607 | 15/45 |
|-------|---|-------------|-----------|-------|



The SSI is initially in the idle mode, where the DATA and CLOCK lines stay HIGH① and the slave keeps updating its internal data. The transmission mode is evoked when the master initiates a sequence by pulling the CLOCK line to LOW. Once, the slave receives the resulting falling edge② at the CLOCK signal line, it automatically stops updating its internal data. With the first rising edge③ at the CLOCK line, the MSB of the sensor data is transmitted and with consequent rising edges, the data bits are sequentially transmitted over the DATA line. After the transmission of the complete data word④ (e.g. LSB is transmitted), an additional last rising edge⑤ at the CLOCK line sets the CLOCK to HIGH. The slave sets or leaves the DATA line to LOW and remains there for the monoflop time t_m , to recognize the transfer timeout. If a falling edge at the CLOCK line (Data-Output request) is received within the monoflop time t_m , the same data as before will be transmitted again (Multiple transmission). If there were no clock pulses within the monoflop time t_m , the slave starts updating its internal data after setting the DATA line to HIGH (Idle mode). This marks the end of the data word transmission (Single transmission). Once the slave receives a clock signal at a time t_p ($\geq t_m$), the updated position data is frozen and the transmission of the new data begins as described earlier.

3.8.3 Wiring

The connection of the PGL-Series sensor to use the SSI interface with a SSI master (e.g. PLC) is shown in Figure 3-11. For details about the cable characteristics and the possible cable length (depends on data rates) see the specifications in chapter 3.8.1. The data rates must be set at the SSI master side.

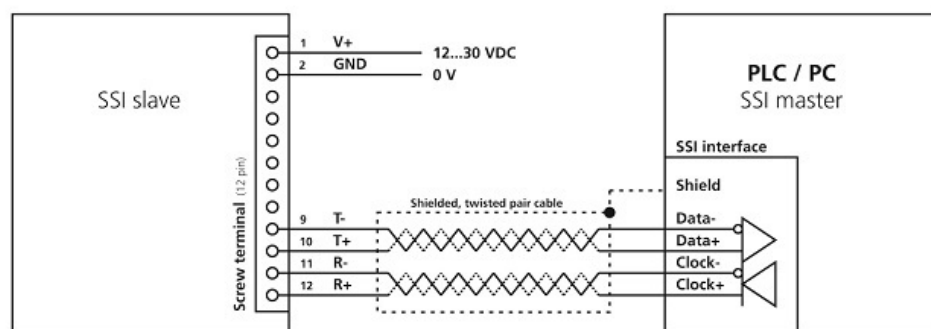

Figure 3-11: Connection of SSI interface with a master device



Never connect multiple PGL-Series devices on a single SSI line.



Use shielded twisted pairs cables only. For details see 3.9.1 Specifications.

3.9 USB interface

The USB interface is also mainly used for the device configuration. It allows the connection with a USB host (e.g. PC) to do the configuration with a terminal program (e.g. HTerm, HyperTerminal) or the Distance Sensor Utility software.

The communication protocol is ASCII based, easy to understand and simple to use. It's the same protocol used for all configuration and other serial interfaces (RS-232, RS-422 / 485 and USB).

For more details about the communication protocol and the available commands see 6 Command set.

| | | | | |
|-------|---|-------------|-----------|---------|
| Title | PGL-050W3/180W3 Technical Reference Manual | Drawing No. | C-41-2607 | 16 / 45 |
|-------|---|-------------|-----------|---------|



3.9.1 Specifications & Wiring

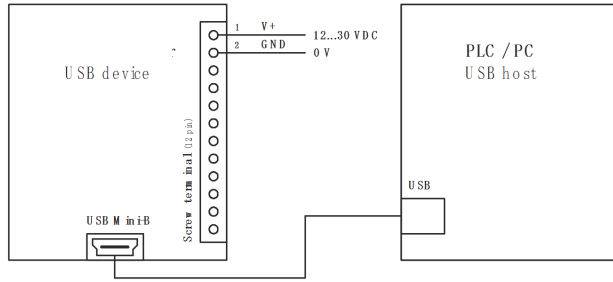

Figure 3-12: Connection of USB interface

Specifications for USB interface:

- USB Mini type B
- USB 2.0 FS (Full speed, max. 12 Mbps)
- Virtual COM port for PGL-Series device
- PGL-Series devices are not powered over USB interface (use separate power supply for the sensors)
- For other information not mentioned at this point, see the USB specifications and guidelines

The connection and wiring to use the USB Mini-B interface is shown in figure.

3.9.2 Installation

The USB interface of the PGL-Series sensor needs a basic USB driver installed on the host system. This has to be done only one time. If the driver installation was successful the PGL-Series laser sensor will be identified correctly by the host system. The USB driver is installed automatically when the Distance Sensor Utility software is installed.

The PGL-Series sensor is identified as a virtual COM port device with the device name “PGL-Series USB Serial Port (COMxx)”. Check the device manager for the COM port number. This number is required to connect to the sensor with a terminal program or the Distance Sensor Utility software (for more details please see Hokuyo website www.hokuyo-aut.jp). The baud rate is the same as the baud rate configured for the other serial interfaces (RS-232 and RS-422 / 485).



Only use the USB driver in conjunction with the PGL-Series USB port. Use the same baud rate for the USB interface as for the other serial interfaces (RS-232 and RS-422 / 485).

4. Configuration

The PGL-Series laser distance sensor has a multiplicity of configuration options. On the one hand the integrated interfaces can be configured (e.g. baud rate of the serial interfaces) to reach a wide range of application requirements. Otherwise it's also possible to configure the behavior of the sensors (e.g. measurement characteristic).

The following table shows an overview of all configuration options and the corresponding references to the commands or chapters.

| Interfaces / Features | Configuration possibilities | Commands |
|-------------------------|--|---|
| Digital input | Input functions (Trigger single measurement, trigger tracking, etc.) | 6.3.5 Set/Get digital input function (sNDI1) |
| Digital output | Output type (NPN, PNP, Push-Pull) | 6.3.3 Set/Get digital output type (sNot) |
| | Switching level (ON / OFF level) | 6.3.4 Set/Get digital output hysteresis (sN1, sN2) |
| RS-232, RS-422 / RS-485 | Communication settings (Baud rate, etc.) | 6.3.1 Set communication settings (sNbr) |
| | Sensor ID | 6.3.2 Set device ID (sNid) |
| SSI | Communication settings (Data format, coding, etc.) | 6.3.7 Set/Get configuration of RS-422/SSI |
| | Error behavior | Set/Get error value of SSI output |
| - | | |
| Sensor behavior | Operation mode (see description in chapter 4.2) | 6.3.11 Set auto start configuration (sNA) |
| | Measurement characteristic (see description in chapter 4.3) | 6.3.9 Set/Get measuring characteristic (sNmc) |
| | Data output (Filter, gain, offset, format) (see description in chapter 4.4) | 6.3.10 Set/Get measurement filter configuration (sNfi) 6.4.2 Set/Get user distance offset (sNuof) 6.4.3 Set/Get user distance gain (sNuga) 6.4.1 Set/Get user output format (sNuo) |

4.1 Configuration process

The configuration process describes how the sensors can be configured. There are different interfaces for connection available and also two configuration types.

4.1.1 Connection

To be able to configure a PGL-Series sensor it has to be powered and connected to a host (usually a PC). On the host side a terminal program (e.g. HTerm, HyperTerminal) can be used to communicate with the sensor. A configuration utility software is also available on the Hokuyo web page (see Distance Sensor Utility software at www.hokuyo-aut.jp).

Connections available for configuration (see figure for details):

RS-232 interfaces

USB interface

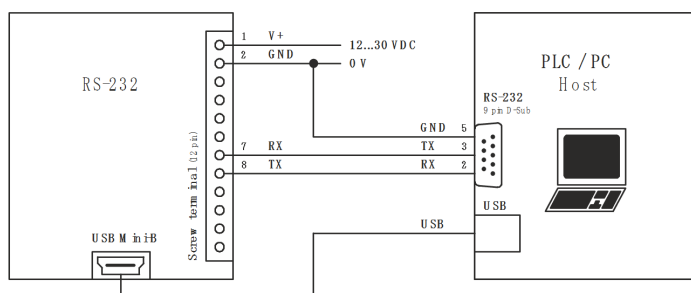

Figure 4-1: Connection of the RS-232 or USB interface for sensor configuration

The specifications for the RS-232 or the USB interface are described in 3.7 RS-232 interface or 3.10 USB interface. The connection for using the RS-232 or the USB interface for configuration is shown in figure Figure.

RS-232 / USB default settings of the PGL-Series device:

COM port: depends on PC / PLC
Baud rate: 19'200 Baud
Data bits: 7
Parity: Even
Stop bits: 1

Title

PGL-050W3/180W3
Technical Reference Manual

Drawing
No.

C-41-2607

18/45



4.1.2 Configuration types

The PGL-Series sensor can be configured with or without saving the configuration changes in the internal memory by using the save command (see 6.3.16 Save configuration parameters (sNs)). So there exist two types of using the configurations, volatile or non-volatile. To find out what configuration type should or can be used for a specific application see the description below.

The PGL-Series sensor supports two configuration types (volatile and non-volatile, see the table below):

Volatile (after every power up cycle, the configuration will be set)

Non-volatile (only one-time configuration, the configuration will be set and saved in sensor memory)

| Steps | Volatile | | Non-volatile |
|---------------|----------|-------------------------------------|--|
| Power up | | | |
| Configuration | 1 | Configuration (all used features) | Configuration (all used features) |
| | 2 | - (no save, volatile configuration) | Save configuration (save configuration in sensor memory) |
| Measurement | 3 | Measurement 0 | Measurement 0 |
| | 4 | Measurement 1 | Measurement 1 |
| | 5 | ... | ... |
| | n | Measurement n | Measurement n |
| Power down | | | |
| Power up | | | |
| Configuration | 1 | Configuration (all used features) | - (not required) |
| Measurement | 2 | Measurement 0 | Measurement 0 |
| | 3 | Measurement 1 | Measurement 1 |
| | 4 | ... | ... |
| | n | Measurement n | Measurement n |

4.2 Operation modes

The PGL-Series laser distance sensors offer two types of operation modes, the controlled mode and the stand-alone mode to cover a wide range of applications. While the controlled mode provides maximum flexibility and needs to be triggered by a host system, the stand-alone mode can operate autonomously. Often it's not suitable or welcome to control a device by the host system in an existing environment. In such cases the stand-alone mode might be preferred. The two types of operation modes are described in the table below.

| Controlled mode | Stand-alone mode | |
|--|--|--|
| | Auto start | Manual start |
| The distance measurement is controlled / triggered by a host system. The available commands listed below: sNg → Distance measurement sNh → Single sensor tracking sNf → Tracking with buffering | The distance measurement starts automatically after a power on cycle. The available command is listed below: sNA → Auto start configuration | An external signal triggers distance measurements. This is possible by configuring the digital input DI1. The available command is listed below: sNDI → Digital input functions |
| See 6.2 Operation commands for more details. | See 6.3.11 Set auto start configuration (sNA) for more details. | See 6.3.5 Set/Get digital input function (sNDI1) for more details. |

All interfaces of the laser sensor are updated internally (with new distance measurements or error codes) independently of the operation mode.

| | | | | |
|-------|---|-------------|-----------|---------|
| Title | PGL-050W3/180W3 Technical Reference Manual | Drawing No. | C-41-2607 | 19 / 45 |
|-------|---|-------------|-----------|---------|



4.2.1 Controlled mode

In controlled mode each action / operation of the PGL-Series sensor is triggered by a command sent from a host system over a serial interface (RS-232, RS-422 / 485 or USB). The basic configuration steps to use the controlled mode are listed in the table below.

| Steps | Action | Description | Commands |
|-------|------------------------------|---|---|
| 1 | Clear device | Clear the device before using the controlled mode by doing a clear followed by a save command. It's also possible to do a device reset (Factory default of the laser sensor) | 6.2.1 Stop / Clear command (sNe) 6.3.13 Save configuration parameters (sNs) 3.2 Reset push button |
| 2 | Set communication parameters | Configure the desired communication parameters and device ID. | 6.3.1 Set communication settings (sNbr) 6.3.2 Set device ID (sNid) |
| 3 | Operation | Use the operation commands to do distance measurements or to use other sensor functionality. | 6.2 Operation commands |

For this operation mode a host software is required to control the PGL-Series laser distance sensor. Careful testing of the host software together with the device is strongly recommended prior to installation.

4.2.2 Stand-alone mode

The stand-alone mode is grouped in auto start configuration and manual start configuration. For details about the functionality and the configuration steps see the following sections.

Auto start configuration

The following steps are needed to configure the PGL-Series sensor for the stand-alone mode with auto start configuration. In this mode the distance measurement is started automatically after every power-up cycle. No external trigger or command is required to start measurement.

All sensor interfaces are updated internally with distance or error data.

| Steps | Action | Description | Commands |
|-------|----------------------------------|--|---|
| 1 | Clear device | Clear the device before using the stand-alone mode by doing a clear followed by a save command. It's also possible to do a device reset (Factory default of the laser sensor) | 6.2.1 Stop / Clear command (sNe) 6.3.13 Save configuration parameters (sNs) 3.2 Reset push button |
| 2 | Set the auto start configuration | Configure the PGL-Series device to the stand-alone mode with auto start. It's possible to select a desired sample rate. For more details see the command description. | 6.3.11 Set auto start configuration (sNA) |



Manual start configuration

The following steps are needed to configure the PGL-Series sensor for the stand-alone mode with manual start configuration. In this mode the distance measurement can be triggered by an external signal event on the digital input (DI1). There are different actions of the PGL-Series sensor available. All sensor interfaces are updated internally with distance or error data.

| Steps | Action | Description | Commands |
|-------|--------------------------------|--|---|
| 1 | Clear device | Clear the device before using the stand-alone mode by doing a clear followed by a save command. It's also possible to do a device reset (Factory default of the laser sensor) | 6.2.1 Stop / Clear command (sNc) 6.3.13 Save configuration parameters (sNs) 3.2 Reset push button |
| 2 | Set the digital input function | Configure the PGL-Series device to react on a trigger event on the digital input (DI1) with a distance measurement. There are different actions available. For more details see the configuration command. | 6.3.5 Set/Get digital input function (sNDI1) |
| 3 | Save configuration | The save configuration command stores this configuration in a non-volatile memory. The configuration persist in the device after a power cycle. | 6.3.13 Save configuration parameters (sNs) |

4.2.3 Error behavior

In case of a device, configuration or measurement error the PGL-Series sensor shows the error on the available sensor interfaces (Status LED's, analog output, digital outputs, RS-232, etc.). On the configurable interfaces the error code is transmitted according this configuration.

The error will be automatically cleared after another successful distance measurement, performing a stop / clear command (see chapter 6.2.1 Stop / Clear command (sNc)) or a power cycle.

The PGL-Series sensor automatically store the occurred measurement errors in a non-volatile error stack. After power-cycle the last errors are still available for diagnostic purpose. The error stack can be read or cleared with the Read/Clear error stack (sNre, sNce) command. For more details about the command, see chapter 6.2.9.

| | | | | |
|-------|---|----------------|-----------|---------|
| Title | PGL-050W3/180W3 Technical Reference Manual | Drawing No. | C-41-2607 | 21 / 45 |
|-------|---|----------------|-----------|---------|



4.3 Measuring characteristic

Multiple measuring characteristics are available in the PGL-Series laser distance sensor to meet different requirements for various applications. With these measuring characteristics measuring rate and accuracy can be optimized for specific application requirements.

The PGL-Series sensor at factory settings has an accuracy of $\pm 3\text{mm}$ (Dxx-10-xxx) at 2σ .

Measuring rate depends on environmental conditions such as target surface, distance, background light (e.g. sun light), etc. Good environmental conditions increase measuring rate (e.g. white target surface or orange reflective target plate and dark environment).

| Measuring characteristic | | Max measuring rate / output rate | | Typical accuracy @ 2σ | | Description |
|--------------------------|---------------|----------------------------------|-----------------------|------------------------------|--------------------------|---|
| No. | Name | PGL-050W3 | PGL-180W3 | PGL-050W3 | PGL-180W3 | |
| 0 | Normal | 20 Hz 1) | 20 Hz 1) | $\pm 3\text{ mm}$ | $\pm 3\text{ mm}$ | Normal measuring characteristic covers a wide range of applications. Measuring range on natural surface: Typical up to 100 m (depends on device type, see the specifications in 2.1). Configuration command: sNmc+0 2) |
| 1 | Fast | 100 Hz 1) | 100 Hz 1) | $\sim \pm 4.5\text{ mm}$ | $\sim \pm 4.5\text{ mm}$ | Increase measuring rate up to 50 Hz / 250 Hz (depends on device type, see the specifications in 2.1). Configuration command: sNmc+1 2) |
| 2 | Precise | 10 Hz 1) | 10 Hz 1) | $\sim \pm 2.4\text{ mm}$ | $\sim \pm 2.4\text{ mm}$ | Increase accuracy with longer measurement to $\sim \pm 0.8\text{ mm}$ / $\sim \pm 2.4\text{ mm}$ (depends on measuring conditions). To generally increase measuring performance, consider 5.3 Measuring performance influence. Configuration command: sNmc+2 2) |
| 3 | Timed | User programmed 100 Hz | User programmed 50 Hz | variable | variable | Timed measuring characteristic allows user defined measuring rates. The device does not consider measuring conditions to reach the specified accuracy. The measuring rate is fixed and the accuracy is variable (depends on measuring conditions). Configuration command: sNmc+3 2) |
| 4 | Moving target | 100 Hz 3) | 50 Hz | $\pm 3\text{ mm}$ | $\pm 3\text{ mm}$ | Moving target measuring characteristic is specific designed for measurements on fast moving targets. For reliable measuring results a good measuring signal is mandatory (good measuring conditions). Configuration command: sNmc+4 2) |
| 5 | Not used | - | - | - | - | - |

1)The measuring rate depends on environmental conditions, see 5.3 Measuring performance influence. For good conditions the specified max. measuring rate can be reached. For bad conditions the measuring rate decrease.

2)For more details about the configuration command, see 6.3.9 Set/Get measuring characteristic (sNmc).

3)Output rate is fixed to 100 Hz for serial interfaces RD-232,RS-422/485, and SSI.

4.4 Data output

The data output of the PGL-Series laser distance sensor is configurable with a wide range of possibilities (output format, user gain, user offset and some filter options). The details about the available configurations are described in the following chapters.

The figure gives an overview of the configuration possibilities and shows the effect on the PGL-Series device interfaces. Please consider not all interfaces are affected in the same manner. For example, the user output format and user gain / offset are only available on the serial interfaces RS-232, RS-422/485 and USB.

| | | | | |
|-------|---|-------------|-----------|---------|
| Title | PGL-050W3/180W3 Technical Reference Manual | Drawing No. | C-41-2607 | 22 / 45 |
|-------|---|-------------|-----------|---------|



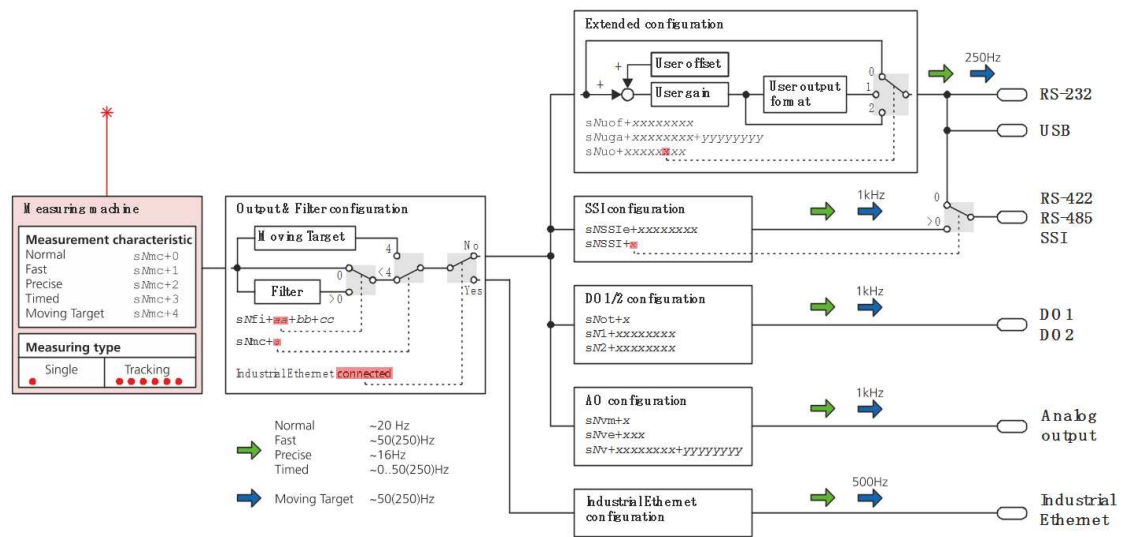

Figure 4-2: Configuration possibilities and flow chart of data output.

Colored arrows show the interface update rate depending on the available measurement characteristics.

4.4.1 User output format / protocol

The configurable output format / protocol of the PGL-Series sensor allows the connection of an external ASCII display or the possibilities to set an individual user distance offset and / or user gain. The user output format is only available on the serial interface RS-232, RS-422/485 and USB.

The configuration command sNuo can be used to select the desired output format and to set some additional settings used for the external ASCII display (field length and position of decimal point). For more details see 6.4.1 Set/Get user output format (sNuo).

| The available output format with an example are listed below: | Configuration example | Output |
|---|---|--------------------|
| Default output format (Factory default) | sNuo+0 (User offset / gain configuration ignored) | "g0g+00012345¥r¥n" |
| Display output format (For external ASCII display) | sNuo+139, sNuga+1+10, sNuof+0 (User offset / gain configuration considered) | " 1.234" |
| Default format with user offset / gain active | sNuo+200, sNuga-1+1, sNuof-10000 (User offset / gain configuration considered) | "g0g-00002345¥r¥n" |



The user output format is only available on the serial interface RS-232, RS-422/485 and USB.

4.4.2 User gain / offset

The user gain and offset configuration of the PGL-Series sensor allows individual and application dependent offset and gain settings. For example, an individual gain configuration enables the conversion to other distance units (e.g. m, inch, etc.). The calculation of the user distance with user offset and user gain (Defined by numerator and denominator) is shown below.

$$Distance_{User} = (Distance + Offset_{User}) \cdot \frac{GainNum_{User}}{GainDen_{User}}$$

| | |
|--------------|---|
| DistanceUser | User distance with offset and gain in 1/10 mm |
| Distance | Measured raw distance of PGL-Series device in 1/10 mm |
| OffsetUser | User offset (+/-) in 1/10 mm |
| GainNumUser | User gain numerator |
| GainDenUser | User gain denominator in 1/10 mm |

The commands to configure the user offset and user gain are described in 6.4.2 Set/Get user distance offset (sNuof) and 6.4.3 Set/Get user distance gain (sNuga).

| | | | | |
|-------|---|-------------|-----------|---------|
| Title | PGL-050W3/180W3 Technical Reference Manual | Drawing No. | C-41-2607 | 23 / 45 |
|-------|---|-------------|-----------|---------|



4.4.3 Output filter (Distance / error)

The PGL-Series sensor has a configurable output filter for the measurement values (Distance and error codes). There are different filter types available to allow a lot of filter possibilities.

The output filter is available on the following measuring characteristics (for more details about the measuring characteristics, see 4.3 Measuring characteristic):

- Normal
- Fast
- Precise
- Timed

The output value filter is based on a moving average filter and supports in addition a spike suppression filter and error suppression filter. The filter functionality are described in the table below. The configuration command of the supported filter types are described in 6.3.13 Set/Get measurement filter configuration (sNfi).

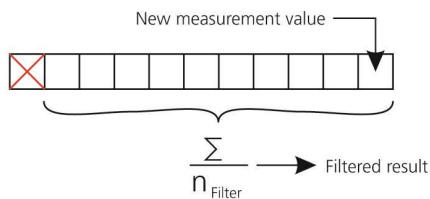

Moving average filter

The moving average filter averages a specified number of measurements. A maximum of 32 measurement values can be averaged (Length of filter is configurable). If a new measurement value is present, this value will be added to the filter values, while the latest value will be removed. The sum of all measurement values divided by the size of the filter is the filtered measurement value and transmitted to all outputs.

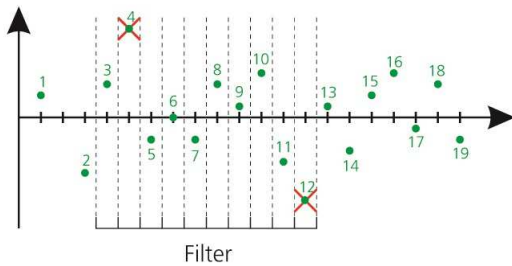

Spike suppression filter

The spike suppression filter eliminates pairs of minimum and maximum values inside the filter values (Number of eliminated minimum / maximum pairs is configurable). Always the lowest and highest values are removed from the average filter calculation.

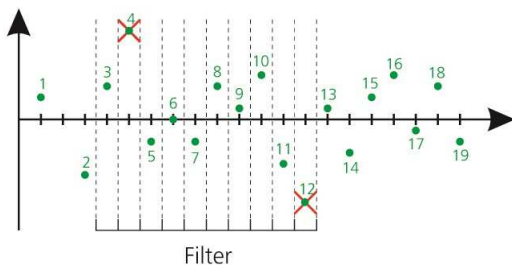

Error suppression filter

A maximum number of errors inside the average filter values can be suppressed (Number of suppressed errors is configurable). If the number of errors inside the average filter values is smaller than the specified number of error suppression, no error is shown at the output.

4.5 Factory settings

The following table shows the default sensor configuration (factory settings). These configurations are set in a new sensor or after a successful reset. To reset the device to the factory default, see the reset process described in 3.2 Reset push button.

| | |
|---|---|
| Configuration parameter | Factory default |
| Digital input 1 (DO1/DI1) | Inactive |
| Digital output type (DO1, DO2, DOE) | NPN output type |
| Digital output 1 (DO1/DI1) | ON level: 2005 mm OFF level: 1995 mm |
| Digital output 2 (DO1/DI1) | ON level: 995 mm OFF level: 1005 mm |
| Analog output | 4~20 mA for 0~10 m distance 0 mA in error case |
| Sensor ID | 0 |
| Serial communication settings (RS-232, RS-422 / RS-485) | 7 (19'200 Baud, 7 data bits, parity even, 1 stop bit) |
| RS-422 / RS-485 | RS-422 / RS-485 active |
| SSI interface | SSI Inactive Data coding: Binary Data format: 24-Bit Error value: No error state and error code added 0 |
| Sensor behavior – Operation mode | Controlled mode (Autostart inactive) |
| Sensor behavior – Measurement characteristic | 0 (Normal) |
| Sensor behavior – Data output | Gain: 1 Offset: 0 mm Format: 0 (Default commands answers, no display output format) Filter: Inactive |

5. Operation

5.1 Measurement overview

The PGL-Series laser distance sensor supports different measurement possibilities to cover high variety of applications. The table below shows the available distance measurement commands and some basic commands. The distance measurement commands are separated in two groups. The “Distance measurement” group commands can be used for one or more sensors on a single line (e.g. multiple sensors on the RS-422 interface). The other command group “Single distance measurement” is only for one sensor on a single line. Otherwise there could be communication problems.

| Group | Measurement possibilities | Commands |
|---|---|--|
| Basic measurement (one or more sensors on a single line) | Clear sensor / Stop measurement | 6.2.1 Stop / Clear command (sNc) |
| | Laser on (Pointing for sensor adjustment) | 6.2.10 Laser on (sNo) |
| | Signal measurement (Single tracking possible) | 6.2.7 Signal measurement (sNm) |
| | Temperature measurement | 6.2.8 Temperature measurement (sNt) |
| | Read / Clear error stack | 6.2.9 Read/Clear error stack (sNre, sNce) |
| Distance measurement (one or more sensors on a single line) | Distance measurement | 6.2.2 Distance measurement (sNg) |
| | Tracking distance measurement with buffering | 6.2.5 Tracking with buffering – Start (sNf) |
| | | 6.2.6 Read out – Tracking with buffering (sNq) |
| Single distance measurement (only one sensor on a single line) | Single tracking distance measurement | 6.2.3 Single sensor tracking (sNh) |
| | Single tracking distance measurement with timer | 6.2.4 Single sensor tracking with timer (sNh) |

Title

PGL-050W3/180W3
Technical Reference Manual

Drawing
No.

C-41-2607

25 / 45



HOKUYO AUTOMATIC CO.,LTD.

5.2 Installation

5.2.1 Connection of the device

The connection of the PGL-Series laser distance sensor is done with two screw terminal plugs. It's essential to do the connections of the device according the following sequence:

- Check if power supply is off and used interfaces do not already transmit data
- Wiring of the crew terminal plugs with used ports (Power supply and used device interface)
- Connect the screw terminal plugs (First the screw terminal plug with power supply)
- Switch on the power supply

The device is read for operation



Never connect the screw terminal plugs under voltage or if some interfaces are already transmitting data. This may damage the sensor and / or interface. No warranty will be granted on improper handling.

5.2.2 Mounting of the device

Four slotted holes for M4 (or M3) screws and four additional threaded holes with hexagon socket set screws on the sensor side make it easy to mount the PGL-Series sensors.

Always follow all applicable safety regulations and never use the device outside the specifications stated under 2 Technical data.



Be aware of covering the PGL-Series devices for devices measuring form the top to the bottom. Otherwise water on the exchangeable cover may get into the housing through the valve diaphragm.

5.2.3 Mounting of reflective plate

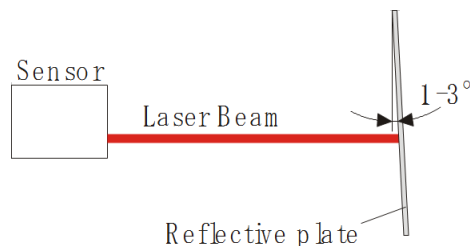

Figure 5-1: Mounting of reflective plates

Measuring to the reflective plate may generate erroneous measurements, if the reflective plate is mounted exactly at an angle of 90° to the laser beam. Therefore mount the reflective plate like shown in Figure 5-1. This prevents the device from too high reflections direct to the receiver lens or laser output. Avoid direct sunlight on the reflective plate to increase measurement performance.



The measuring range (min. / max. distance) on the reflective plate depends on the device type. Please check the device specifications in chapter 2.1 for detailed information.

5.2.4 Alignment of the laser beam

Alignment of the laser beam is often difficult when the target is far away. Maybe a coarse alignment at a nearer target distance helps for such difficulties.

5.3 Measuring performance influence

The PGL-Series laser distance sensors are optical instruments, whose operation is influenced by environmental conditions. Therefore the measuring range and speed achieved in a specific application may vary. The following conditions can influence the measuring range and speed in a positive or negative manner:

| Keywords | Factors increasing range / speed | Factors reducing range / speed |
|--------------------|--|---|
| Target surface | Bright, matt and flat natural surfaces. Optimal natural surfaces: white, matt and flat Reflective surfaces such as the orange target plates | Rough and dark surfaces |
| Airborne particles | Clean air | Dust, fog, heavy rainfall, heavy snowfall |
| Sunlight | Darkness, no sunlight | Bright sunlight on the target |

The measurement range may also be influenced by the configuration of the measurement characteristic. See the descriptions of the measuring characteristics in 4.3 Measuring characteristic. The PGL-Series sensor does not compensate the influence of the atmospheric environment, which may be relevant when measuring long distances (e.g. > 180 m).

5.4 Prevention of erroneous measurements

This chapter should help to prevent erroneous measurement with the PGL-Series laser distance sensors. Please consider the following notes in the corresponding applications. There are further information on the knowledge base on the Hokuyo website (www.hokuyo-aut.jp).

5.4.1 Rough surfaces

On a rough surface (e.g. coarse plaster) measure against the center of the illuminated area. To avoid measuring to the bottom of gaps in the surface use a target plate or board (see accessories on www.hokuyo-aut.jp).

5.4.2 Transparent surfaces

To avoid measuring errors, do not measure against transparent surfaces such as colorless liquids (such as water) or (dust-free) glass. In case of unfamiliar materials and liquids, always carry out a trial measurement.



Erroneous measurements can occur when aiming through glass panes or if there are several objects in the line of sight.

5.4.3 Wet, smooth or high-gloss surfaces

Aiming at an “acute” angle deflects the laser beam. The PGL-Series sensor may receive a signal that is too weak (error message 255) or it may measure the distance targeted by the deflected laser beam.

If aiming at a right angle, the PGL-Series sensor may receive a signal that is too strong (error message 256).

5.4.4 Inclined, round surfaces

Measurement is possible as long as there is enough target surface area for the laser spot. On irregular and round surfaces the arithmetic average of the illuminated surfaces will be measured.

5.4.5 Multiple reflections

Erroneous measurements may occur if the laser beam is reflected by other objects than the target. Avoid any reflective object along the measurement path.

| | | | | |
|-------|---|----------------|-----------|---------|
| Title | PGL-050W3/180W3 Technical Reference Manual | Drawing No. | C-41-2607 | 27 / 45 |
|-------|---|----------------|-----------|---------|



5.4.6 Influence of sun light

Aiming directly to the sun or the sun is exactly behind the target could make it impossible to measure distances.

5.5 Laser life time consideration

Since the life time of the laser is limited, operate the device in a way, that the laser is switched on only when necessary. The laser life time stated under 2.1 Specifications relates to the time while the laser is on.

The following conditions affects the laser life time in a positive manner:

Low ambient temperature (high temperatures reduce laser life time)

Switch laser off if possible (only do continuous measurements if necessary)

6. Command set

6.1 General

6.1.1 Command termination

Every command for the PGL-Series devices are ASCII based and terminated with <CrLf> at the end of every command. The PGL-Series devices command answers are terminated in the same manner (<CrLf>).

6.1.2 Device identification N

The PGL-Series sensor can be addressed with a configurable device ID. This ID is represented in the commands by the placeholder N. At the location of N insert the Device ID.

6.1.3 Parameter separator

The command syntax uses the '+' sign as parameter separator. The '+' sign can be replaced by the minus '-' sign if applicable by the command.

6.1.4 Set/Get commands

All configuration commands of the PGL-Series sensor are used to set new configuration values. The same command without a configuration value can also be used to read the set value. The corresponding command syntax is described with an example command (sNeg) below:

| | Set command | Get command |
|-------------------|----------------------|---|
| Command | sNeg+aaaaaaaa<CrLf> | sNeg<CrLf> |
| Return successful | gNeg?<CrLf> | gNeg+aaaaaaaa<CrLf> |
| Return error | gN@Ezzz<CrLf> | gN@Ezzz<CrLf> |
| Parameters | N aaaaaaaa zzz | Device ID Command parameter / configuration value; + positive / - negative Error code |

6.1.5 Startup sequence

After power-on, the PGL-Series sensor does the initialization and afterward a startup string gN? over the serial interfaces. As described before, N is the placeholder for the device ID of the connected PGL-Series sensor. After sending this startup string, the PGL-Series device is ready to use.



6.2 Operation commands

6.2.1 Stop / Clear command (sNc)

Stops the current execution and resets the status LEDs as well as the digital outputs.

| | | |
|-------------------|---------------|-------------------------|
| | Command | |
| Command | sNc<CrLf> | |
| Return successful | gN?<CrLf> | |
| Return error | gN@Ezzz<CrLf> | |
| Parameters | N zzz | Device ID Error code |

6.2.2 Distance measurement (sNg)

Triggers simple measurement of distance. Each new command cancels an active measurement.

| | | |
|-------------------|----------------------|--|
| | Command | |
| Command | sNg<CrLf> | |
| Return successful | gNg+aaaaaaaa<CrLf> | |
| Return error | gN@Ezzz<CrLf> | |
| Parameters | N aaaaaaaa zzz | Device ID Distance in 1/10 mm Error code |

6.2.3 Single sensor tracking (sNh)

Triggers continuous measurements of the distance. The measurements are made as fast as possible (Measurement speed depends on target conditions). This command must not be used with more than one PGL-Series devices on a RS-232/RS-422 line. The measurements are continued until the Stop / Clear command (sNc) is issued. The status LEDs and the digital outputs are updated corresponding to the new measured distance.



Never use this command if more than one device is connected to the serial interfaces.

| | | |
|-------------------|----------------------|---|
| | Command | |
| Command | sNh<CrLf> | |
| Return successful | gNh+aaaaaaaa<CrLf> | |
| Return error | gN@Ezzz<CrLf> | |
| Parameters | N aaaaaaaa zzz | Device ID Distance in 0.1 mm Error code |



6.2.4 Single sensor tracking with timer (sNh)

This command does the same as the sNh command.



Never use this command if more than one device is connected to the serial interfaces.

| | | |
|-------------------|----------------------------|---|
| | Command | |
| Command | sNh+aaa<CrLf> | |
| Return successful | gNh+bbbbbbb<CrLf> | |
| Return error | gN@Ezzz<CrLf> | |
| Parameters | N aaa bbbbbbb zzz | Device ID Sampling time in 1 ms (Range: 0...4000, 0 → max possible rate) Distance in 0.1 mm Error code |

6.2.5 Tracking with buffering - Start (sNf)

Triggers continuous measurements of the distance with internal buffering in the device (buffer for one measurement). The rate of measurements is defined with the sampling time. If the sampling time is set to zero, the measurements are executed as fast as possible (Measuring speed depends on target conditions). The last measurement can be read out from the module with the command sNq. The measurements are continued until the sNc command is issued.

| | | |
|-------------------|----------------------|---|
| | Set command | Get command |
| Command | sNf+aaa<CrLf> | sNf<CrLf> |
| Return successful | gNf?<CrLf> | gNf+aaaaaaaa<CrLf> |
| Return error | gN@Ezzz<CrLf> | gN@Ezzz<CrLf> |
| Parameters | N aaaaaaaa zzz | Device ID Sampling time in 1 ms (Range: 0...4000, 0 → max possible rate) Error code |

6.2.6 Read out - Tracking with buffering (sNq)

After starting “tracking with buffering” with the command sNf, the latest measurement can be read out from the module with the command sNq. This command does not work if the tracking with buffering is not started.

| | | |
|-------------------|---------------------------|--|
| | Command | |
| Command | sNq<CrLf> | |
| Return successful | gNq+aaaaaaaa+b<CrLf> | |
| Return error | gN@Ezzz+b<CrLf> | |
| Parameters | N aaaaaaaa b zzz | Device ID Distance in 0.1 mm 0 → No new measurement since last sNq command 1 → One new measurement since last sNq command, not overwritten 2 → More than one measurement since last sNq command, overwritten Error code |



When connecting with RS485, after sending the command sNf, it will reply immediately from this device. (about 100 μs)
Cannot be used if it takes time to switch the receiving side of your RS485 device.



6.2.7 Signal measurement (sNm)

Signal measurement can be done continuously or with a single measurement. The signal strength is returned as a relative number in the typical range of 0 to ~25'000. The value for the signal strength is just an approximate value, it differs from device to device, device series and also depends on environment conditions.



Never use the command sNm+1 if more than one device is connected to the serial interfaces.

| | | |
|-------------------|-------------------------------|--|
| | Command | |
| Command | sNm+a<CrLf> | |
| Return successful | gNm+bbbbbbbb<CrLf> | |
| Return error | gN@Ezzz<CrLf> | |
| Parameters | N a bbbbbbbb zzz | Device ID 0 → Single measurement 1 → Repetitive measurements (Warning: Use with one device only!) Signal strength (range 0.. ~25'000) Error code |

6.2.8 Temperature measurement (sNt)

Triggers measurement of the temperature of the device.

| | | |
|-------------------|---------------------|---|
| | Command | |
| Command | sNt<CrLf> | |
| Return successful | gNt+aaaaaaa<CrLf> | |
| Return error | gN@Ezzz<CrLf> | |
| Parameters | N aaaaaaa zzz | Device ID Temperature in 0.1°C Error code |

6.2.9 Read/Clear error stack (sNre, sNce)

Reads or clears the error stack of the device. The errors in the error stack are stored permanently until a clear error stack command (sNce) is done.

| | | |
|-------------------|-------------------------------|--|
| | Read command | Clear command |
| Command | sNre<CrLf> | sNce<CrLf> |
| Return successful | gNre+aaa+aaa+aaa+.. <CrLf> | gNce?<CrLf> |
| Return error | gN@Ezzz<CrLf> | gN@Ezzz<CrLf> |
| Parameters | N aaa zzz | Device ID List of occurred error codes (stored since last error stack clear command sNce) First list entry is the last occurred error code, 0 → No error). Error code |

6.2.10 Laser on (sNo)

Switches the laser beam on for easy sensor adjustment.

| | | |
|-------------------|---------------|-------------------------|
| | Command | |
| Command | sNo<CrLf> | |
| Return successful | gN?<CrLf> | |
| Return error | gN@Ezzz<CrLf> | |
| Parameters | N zzz | Device ID Error code |



6.3 Configuration commands

6.3.1 Set communication settings (sNbr)

Sets the communication settings for the serial interface RS-232 / RS-422 / RS-485. The settings number 7 (marked with gray) is the default communication setting (factory default or after a device reset).



A change in the communication setting number will be activated after power off sequence.

| | Command | | | | | | | | | | | | | | | | | | | | | | | | | | | | | | | | | | | | | | | | | | | | | | | | | | | |
|-------------------|--------------------|--|--------|-----------|-----------|--------|-----------|---|------|---|------|---|---|-------|---|------|---|---|------|---|------|---|---|------|---|------|---|---|-------|---|------|---|---|-------|---|------|---|---|-------|---|------|---|----|--------|---|------|---|----|--------|---|------|---|
| Command | sNbr+aa<CrLf> | | | | | | | | | | | | | | | | | | | | | | | | | | | | | | | | | | | | | | | | | | | | | | | | | | | |
| Return successful | gNbr?<CrLf> | | | | | | | | | | | | | | | | | | | | | | | | | | | | | | | | | | | | | | | | | | | | | | | | | | | |
| Return error | gN@Ezzz<CrLf> | | | | | | | | | | | | | | | | | | | | | | | | | | | | | | | | | | | | | | | | | | | | | | | | | | | |
| Parameters | N aa zzz | Device ID Number of communication setting: <table border="1"> <thead> <tr> <th>aa</th> <th>Baud rate</th> <th>Data bits</th> <th>Parity</th> <th>Stop bits</th> </tr> </thead> <tbody> <tr> <td>1</td> <td>9600</td> <td>8</td> <td>None</td> <td>1</td> </tr> <tr> <td>2</td> <td>19200</td> <td>8</td> <td>None</td> <td>1</td> </tr> <tr> <td>5</td> <td>4800</td> <td>7</td> <td>Even</td> <td>1</td> </tr> <tr> <td>6</td> <td>9600</td> <td>7</td> <td>Even</td> <td>1</td> </tr> <tr> <td>7</td> <td>19200</td> <td>7</td> <td>Even</td> <td>1</td> </tr> <tr> <td>8</td> <td>38400</td> <td>8</td> <td>None</td> <td>1</td> </tr> <tr> <td>9</td> <td>38400</td> <td>7</td> <td>Even</td> <td>1</td> </tr> <tr> <td>10</td> <td>115200</td> <td>8</td> <td>None</td> <td>1</td> </tr> <tr> <td>11</td> <td>115200</td> <td>7</td> <td>Even</td> <td>1</td> </tr> </tbody> </table> Error code | aa | Baud rate | Data bits | Parity | Stop bits | 1 | 9600 | 8 | None | 1 | 2 | 19200 | 8 | None | 1 | 5 | 4800 | 7 | Even | 1 | 6 | 9600 | 7 | Even | 1 | 7 | 19200 | 7 | Even | 1 | 8 | 38400 | 8 | None | 1 | 9 | 38400 | 7 | Even | 1 | 10 | 115200 | 8 | None | 1 | 11 | 115200 | 7 | Even | 1 |
| aa | Baud rate | Data bits | Parity | Stop bits | | | | | | | | | | | | | | | | | | | | | | | | | | | | | | | | | | | | | | | | | | | | | | | | |
| 1 | 9600 | 8 | None | 1 | | | | | | | | | | | | | | | | | | | | | | | | | | | | | | | | | | | | | | | | | | | | | | | | |
| 2 | 19200 | 8 | None | 1 | | | | | | | | | | | | | | | | | | | | | | | | | | | | | | | | | | | | | | | | | | | | | | | | |
| 5 | 4800 | 7 | Even | 1 | | | | | | | | | | | | | | | | | | | | | | | | | | | | | | | | | | | | | | | | | | | | | | | | |
| 6 | 9600 | 7 | Even | 1 | | | | | | | | | | | | | | | | | | | | | | | | | | | | | | | | | | | | | | | | | | | | | | | | |
| 7 | 19200 | 7 | Even | 1 | | | | | | | | | | | | | | | | | | | | | | | | | | | | | | | | | | | | | | | | | | | | | | | | |
| 8 | 38400 | 8 | None | 1 | | | | | | | | | | | | | | | | | | | | | | | | | | | | | | | | | | | | | | | | | | | | | | | | |
| 9 | 38400 | 7 | Even | 1 | | | | | | | | | | | | | | | | | | | | | | | | | | | | | | | | | | | | | | | | | | | | | | | | |
| 10 | 115200 | 8 | None | 1 | | | | | | | | | | | | | | | | | | | | | | | | | | | | | | | | | | | | | | | | | | | | | | | | |
| 11 | 115200 | 7 | Even | 1 | | | | | | | | | | | | | | | | | | | | | | | | | | | | | | | | | | | | | | | | | | | | | | | | |

6.3.2 Set device ID (sNid)

Sets the device identification N. The device ID N is used for the most of all commands.

| | | |
|-------------------|----------------|--|
| | Command | |
| Command | sNid+aa<CrLf> | |
| Return successful | gNid?<CrLf> | |
| Return error | gN@Ezzz<CrLf> | |
| Parameters | N aa zzz | Device ID New device ID, range 0~99 Error code |

6.3.3 Set/Get digital output type (sNot)

Sets the output type for all digital outputs. It's possible to select NPN, PNP or Push-Pull outputs.



The configuration of the output type takes effect on all digital outputs (DO1, DO2, DOE).

| | | |
|-------------------|-------------------|--|
| | Set command | Get command |
| Command | sNot+a<CrLf> | sNot<CrLf> |
| Return successful | gNot?<CrLf> | gNot+a?<CrLf> |
| Return error | gN@Ezzz<CrLf> | gN@Ezzz<CrLf> |
| Parameters | N a zzz | Device ID Digital output type (for all digital outputs): 0 → NPN (Low driven, load between V+ and DOx output) 1 → PNP (High driven, load between DOx output and GND) 2 → Push-pull (Low & High driven) Error code |

| | | | | |
|-------|---|-------------|-----------|---------|
| Title | PGL-050W3/180W3 Technical Reference Manual | Drawing No. | C-41-2607 | 32 / 45 |
|-------|---|-------------|-----------|---------|



6.3.4 Set/Get digital output hysteresis (sN1, sN2)

Sets the output hysteresis for the two digital outputs individual. For every output a switching ON / OFF distance hysteresis can be configured. There are two possibilities to configure hysteresis with the ON / OFF levels (1: ON > OFF, 2: ON < OFF):

1) Hysteresis: ON level > OFF level

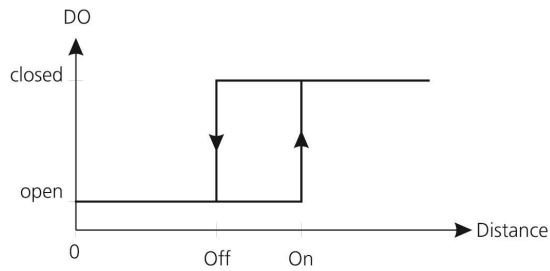

This description and diagram is correct if the ON level of the hysteresis is larger than the OFF level. With an increasing distance, the digital output is switched on (open drain output is closed) when the distance exceeds the ON level. With a decreasing distance, the digital output is switched off (open drain output is open) when the distance falls again below the OFF level. See the diagram on the left side.

2) Hysteresis: ON level < OFF level

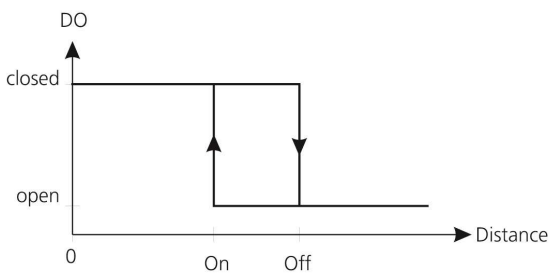

This description and diagram is correct if the ON level of the hysteresis is lesser than the OFF level. With a decreasing distance, the digital output is switched on (open drain output is closed) when the distance falls below the ON level. With an increasing distance, the digital output is switched off (open drain output is open) when the distance exceeds the OFF level. See the diagram on the left side.

| | Set command | Get command |
|-------------------|-------------------------------------|---|
| Command | sNa+bbbbbbb+ccccccc<CrLf> | sNa<CrLf> |
| Return successful | gNa?<CrLf> | gNa+bbbbbbb+ccccccc<CrLf> |
| Return error | gN@Ezzz<CrLf> | gN@Ezzz<CrLf> |
| Parameters | N a bbbbbbb ccccccc zzz | Device ID Digital output port (1 or 2) Distance ON level in 1/10 mm for switching digital output ON Distance OFF level in 1/10 mm for switching digital output OFF Error code |

6.3.5 Set/Get digital input function (sNDI1)

The digital output DO1/DI1 of the PGL-Series sensors can also be used as digital input. The command sNDI1 configures a function / event for the device. The level of the digital input can be read with the command sNRI.



Activation of a digital input function of DI1, deactivate the digital output DO1 automatically.

| | Set command | Get command |
|-------------------|----------------------|---|
| Command | sNDI1+aaaaaaaa<CrLf> | sNDI1<CrLf> |
| Return successful | gNDI1?<CrLf> | sNDI1+aaaaaaaa<CrLf> |
| Return error | gN@Ezzz<CrLf> | gN@Ezzz<CrLf> |
| Parameters | N aaaaaaaa zzz | Device ID Digital input functions: 0 → Digital input DI1 deactivated (Digital output DO1 activated). 2 → Trigger Distance measurement (sNg) 3 → Start/Stop Single sensor Tracking (sNh) 4 → Start/Stop Tracking with buffering (sNf) 8 → Start/Stop Single sensor Timed Tracking (sNh+) Error code |



6.3.6 Get digital input (sNRI)

Reads the digital input level (low / high) of DO1/DI1. Note for the use of DO1 instead of DI1, this command reads the logical level of the digital output.

| | | |
|-------------------|-------------------|---|
| | Command | |
| Command | sNRI<CrLf> | |
| Return successful | gNRI+a<CrLf> | |
| Return error | gN@Ezzz<CrLf> | |
| Parameters | N a zzz | Device ID 0 → Input Off (Signal Low) 1 → Input On (Signal High) Error code |

6.3.7 Set/Get configuration of RS-422/SSI

The SSI interface is not available on all PGL-Series devices (check the device specification, see chapter 2.1) and is deactivated by default. The SSI and the RS-422 interfaces uses the same differential output driver, so only one of them can be activated at the same time.



Only one interface (RS-422 or SSI) can be activated at the same time.

| | | |
|-------------------|---|---|
| | Set command | Get command |
| Command | sNSSI+aaa<CrLf> | sNSSI<CrLf> |
| Return successful | gNSSI?<CrLf> | gNSSI+aaa<CrLf> |
| Return error | gN@Ezzz<CrLf> | gN@Ezzz<CrLf> |
| Parameters | N aaa deactivated) 200) zzz | Device ID Binary coded settings: Bit0 0 → Activate RS-422 interface (SSI is deactivated) 1 → Activate SSI interface with the following settings (RS-422 is deactivated) Bit1 0 → Binary coded data output 1 → Gray coded data output Bit2 0 → No error bit output 1 → Error bit attached to the output data value Bit3 0 → No additional error data output 1 → Attach 8-Bit error data (Calculation: Error data = Error code - 200) Bit4 0 → 24-Bit data value 1 → 23-Bit data value Error code |

Configuration example: SSI activated, 23-Bit data (binary), 8-Bit error data (binary) and error bit

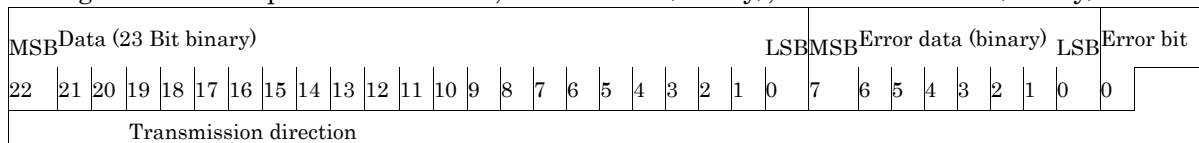

| | |
|----------------|---|
| Configuration: | Binary data: 111012 → 13 Bit0 → 1: SSI interface activated Bit1 → 0: Binary coded data output Bit2 → 1: Error bit attached to the output data value Bit3 → 1: Attach 8-Bit SSI error data (Error code - 200) Bit4 → 1: 23-Bit data value |
| Command: | sNSSI+29 |



6.3.8 Set/Get error value of SSI output

In case of an error the SSI output will show a value corresponding to this configuration. There can be a replacement value in a range of 0 to 16777215 (24-Bit) or 0 to 8388607 (23-Bit), the last valid distance value or the error code. All values are shown either as binary value or gray coded depending on SSI configuration.

| | Set command | Get command |
|-------------------|--------------------------|---|
| Command | sNSSIe+aaaaaaaa<CrLf> | sNSSIe<CrLf> |
| Return successful | gNSSIe?<CrLf> | gNSSIe+aaaaaaaa<CrLf> |
| Return error | gN@Ezzz<CrLf> | gN@Ezzz<CrLf> |
| Parameters | N aaaaaaaa zzz | Device ID 0..224-1 / 0..223-1 → Replacement value (depending on the SSI settings, the value will be converted to gray code). In case of an error, the data value will be replaced by this replacement value. -1 → In case of an error the last distance value will stay at the output. -2 → In case of an error, the error code will be at the output. Error code |

6.3.9 Set/Get measuring characteristic (sNmc)

The PGL-Series sensor provides different measuring characteristics to allow an adjustment of the measuring process of the device. This functionality makes it possible to optimize measuring accuracy and measuring speed for a specific application and its requirement. For detailed information about the available measuring characteristics, see 4.3 Measuring characteristic.

| | Set command | Get command |
|-------------------|--------------------------|--|
| Command | sNmc+aaaaaaaa<CrLf> | sNmc<CrLf> |
| Return successful | gNmc?<CrLf> | gNmc+aaaaaaaa<CrLf> |
| Return error | gN@Ezzz<CrLf> | gN@Ezzz<CrLf> |
| Parameters | N aaaaaaaa zzz | Device ID 0 → Normal 1 → Fast 2 → Precise 3 → Timed 4 → Moving target Error code |

6.3.10 Set/Get measurement filter configuration (sNfi)

The filter applied to the distance measurement values can be configured with the following parameters and guidelines.

| | Set command | Get command |
|-------------------|--------------------------------|---|
| Command | sNfi+aa+bb+cc<CrLf> | sNfi<CrLf> |
| Return successful | gNfi?<CrLf> | gNfi+aa+bb+cc<CrLf> |
| Return error | gN@Ezzz<CrLf> | gN@Ezzz<CrLf> |
| Parameters | N aa bb cc zzz | Device ID Filter length (0 → Filter off, 2...32 → Allowed filter length) Number of spikes to suppress (always pairs of min and max value) Maximum number of errors to suppress. Condition: 2*bb + cc ≤ 0.4*aa Error code |



6.3.11 Set auto start configuration (sNA)

This command activates the stand-alone mode with auto start of the PGL-Series sensor. It triggers continuous measurements of the distance. The analog, digital and SSI outputs are updated according to the measured distance values. The sampling time defines the measurement rate. If the sampling time is set to zero, the measurements are executed as fast as possible (depending on target conditions). The stand-alone mode with auto start is active until the Stop / Clear command (sNc) is received by the device. The Stop / Clear command only suspends the stand-alone mode with auto start temporarily. To deactivate this mode permanently a Save configuration (sNs) command after the Stop / Clear command is necessary.



The operation mode is stored permanently in the device and activated immediately. This mode is activated automatically after power on.



To stop / clear the stand-alone mode with auto start permanently a Save configuration (sNs) command after the Stop / Clear command is necessary.



Internally, "Tracking with buffering" is started (see command: sNf). Therefore, the latest measurement can also be read out from the device with the command sNq.

| | | |
|-------------------|---|--|
| | Command | |
| Command | sNA+aaaaaaaa<CrLf> | |
| Return successful | gNA?<CrLf> | |
| Return error | gN@Ezzz<CrLf> | |
| Parameters | N Device ID aaaaaaaa Sampling time in 1 ms (Range: 0...4000, 0 → max possible rate) zzz Error code | |

6.3.12 Set configuration parameters to factory default (sNd)

This command restores all configuration parameters to their factory default values. The parameters are written to the Flash Memory and therefore permanently saved.



This will also reset the communication settings to the factory default.

| | | |
|-------------------|---|--|
| | Command | |
| Command | sNd<CrLf> | |
| Return successful | gN?<CrLf> | |
| Return error | gN@Ezzz<CrLf> | |
| Parameters | N Device ID zzz Error code | |

6.3.13 Save configuration parameters (sNs)

This command saves all configuration parameters, which are set by the commands above. The parameters are written to the Flash Memory.

| | | |
|-------------------|---|--|
| | Command | |
| Command | sNs<CrLf> | |
| Return successful | gNs?<CrLf> | |
| Return error | gN@Ezzz<CrLf> | |
| Parameters | N Device ID zzz Error code | |



6.4 Extended configuration commands

6.4.1 Set/Get user output format (sNuo)

This command allows the configuration of a user specific output format. The configuration only affects the selected serial interface RS-232, RS-422/485 and USB. For more details about the data output of the PGL-Series sensor, see 4.4 Data output.

The user output format can be configured to fit the requirement of an external ASCII display. A parameter for the output format between 100 and 199 defines the format for an external display (User gain / offset are used too). The parameter (b) defines the field length of the ASCII display (including decimal point). The decimal point will be inserted at the position (counted from the right) defined by the parameter (a). The distance on the display will be right aligned.

It is also possible to use the default output format / protocol (Factory default) with a configured user gain and offset. The command parameter value of 200 sets this default format with activated user gain and offset (6.4.2 Set/Get user distance offset (sNuof) and 6.4.3 Set/Get user distance gain (sNuga).

| | Set command | Get command |
|-------------------|--|---------------------|
| Command | sNuo+aaaaaaaa<CrLf> | sNuo<CrLf> |
| Return successful | gNuo?<CrLf> | gNuo+aaaaaaaa<CrLf> |
| Return error | gN@Ezzz<CrLf> | gN@Ezzz<CrLf> |
| Parameters | N Device ID aaaaaaaaa Output format 0 → Default format (Factory setting), e.g. "g0g+00001234YrYn" 1ab → Display output format (For external display), e.g. "1.234YrYn" a → Number of digits after decimal point b → Field with (sign included) must be greater than 0 Conditions: a ≤ b, if a = b, no decimal point is output. 200 → Default format with user offset / gain active, e.g. "g0g-00000234YrYn" Distance output = (Distance + Offset) * Gain zzz Error code | |

6.4.2 Set/Get user distance offset (sNuof)

The user can set an individual user offset to create a user defined distance output value. This configuration takes effect in all distance measurement commands but only if the corresponding user output format is activated (see 6.4.1 Set/Get user output format (sNuo) for more details). The calculation of the user offset is described in 4.4.2 User gain / offset.



The user distance offset is only considered for the corresponding user output format and on the selected serial interface RS-232, RS422/485 and USB.

| | Set command | Get command |
|-------------------|--|----------------------|
| Command | sNuof+aaaaaaaa<CrLf> | sNuof<CrLf> |
| Return successful | gNof?<CrLf> | gNuof+aaaaaaaa<CrLf> |
| Return error | gN@Ezzz<CrLf> | gN@Ezzz<CrLf> |
| Parameters | N Device ID aaaaaaaaa Offset in 1/10 mm (+/- offset possible) zzz Error code | |



6.4.3 Set/Get user distance gain (sNuga)

The user can set an individual user gain to create a user defined distance output value. This configuration takes effect in all distance measurement commands but only if the corresponding user output format is activated (see 6.4.1 Set/Get user output format (sNuo) for more details). The calculation of the user gain is described in 4.4.2 User gain / offset.



The user distance offset is only considered for the corresponding user output format and on the selected serial interface RS-232, RS422/485 and USB.

| | | |
|-------------------|---|--|
| | Set command | Get command |
| Command | sNuga+aaaaaaaa+bbbbbbb<CrLf> | sNuga<CrLf> |
| Return successful | gNuga?<CrLf> | gNuga+aaaaaaaa+bbbbbbb<CrLf> |
| Return error | gN@Ezzz<CrLf> | gN@Ezzz<CrLf> |
| Parameters | N aaaaaaaa bbbbbbb be zero) zzz | Device ID GainNum → Numerator of gain calculation GainDen → Denominator of gain calculation (Attention: GainDen ≠ 0, must not be zero) Error code |

6.5 Information commands

6.5.1 Get software version (sNsv)

Reads the software version of the PGL-Series sensor.

| | | |
|-------------------|--------------------------|---|
| | Command | |
| Command | sNsv<CrLf> | |
| Return successful | gNsv+aaaabbbb<CrLf> | |
| Return error | gN@Ezzz<CrLf> | |
| Parameters | N aaaa bbbb zzz | Device ID Internal measuring module software version Interface software version Error code |

6.5.2 Get serial number (sNsn)

Reads the serial number of the PGL-Series sensor.

| | | |
|-------------------|----------------------|--|
| | Command | |
| Command | sNsn<CrLf> | |
| Return successful | gNsn+aaaaaaaa<CrLf> | |
| Return error | gN@Ezzz<CrLf> | |
| Parameters | N aaaaaaaa zzz | Device ID Serial number of the device Error code |



6.5.3 Get device type (sNdt, dt)

Reads the device type of PGL-Series sensor.



Never use dt command if more than one device is connected to the serial interfaces.

| | | |
|-------------------|------------------------|--------------------------------|
| | Command | |
| Command | sNdt<CrLf> dt<CrLf> | |
| Return successful | gNdt+0xyy<CrLf> | |
| Return error | gN@Ezzz<CrLf> | |
| Parameters | N | Device ID |
| | x | Device series number |
| | yy | Device number |
| | | Output for 0xyy |
| | | 0401 → PGL-Series laser sensor |
| | zzz | Error code |

6.5.4 Get device generation and type (dg)

Reads the device generation & type of the PGL-Series sensors. The answer includes the device type, device generation and the active communication setting. Works only for newer sensor generations (starting from device generation C).



Never use this command if more than one device is connected to the serial interfaces.

| | | |
|-------------------|-------------------|---|
| | Command | |
| Command | dg<CrLf> | |
| Return successful | gNdg+aaa+bc<CrLf> | |
| Return error | gN@Ezzz<CrLf> | |
| Parameters | N | Device ID |
| | aaa | Bit coded number to identify the device: 0x54 (84) → PGL-Series sensor |
| | b | Internal information |
| | c | Communication settings (see command sNbr) |
| | zzz | Error code |



6.6 Error codes

The following table lists the most important error codes of the PGL-Series sensors. For not listed error codes, please contact Hokuyo.

| No.1) | Format | Description | Troubleshooting |
|------------|--------|--|--|
| 0 | | No error | |
| 200 | | Boot-up event of sensor | Used for error stack to see boot-up of the sensor |
| 203 | @E203 | Wrong command, parameter or syntax | Check command, parameter and communication settings (Baud rate, stop bits, parity and termination). |
| 210 | @E210 | Sensor not in tracking mode | Start tracking measurement first. |
| 211 | @E211 | Tracking measurement time too short | Check the min. possible measurement time of the device. Increase measurement time. |
| 212 | @E212 | Command cannot be executed, while tracking measurement is active | Measurement has to be stopped with Stop / Clear command sNc before execute the new command. |
| 220 | @E220 | Error in the serial communication | Check communication settings (Baud rate, stop bits, parity and termination). |
| 230 | @E230 | Distance value overflow caused by wrong user configuration. | Check user offset / gain configuration. |
| 233 | @E233 | Number cannot be displayed | Check output format |
| 234 | @E234 | Distance not in measurement range | Check measurement setup and distance to the measuring surface / target. |
| 236 | @E236 | Conflict in digital input / output DI1/DO1 configuration | Check digital input / output DI1/DO1 configuration. Only input or output possible, otherwise input / output conflict. |
| 252 | @E252 | Temperature too high | Reduce ambient temperature. Contact HOKUYO if the error occurs at room temperature. |
| 253 | @E253 | Temperature too low | Increase ambient temperature. For device with heater functionality, wait until heater increased temperature. Contact HOKUYO if the error occurs at room temperature. |
| 255 | @E255 | Received signal too low or distance not in range | Check measurement setup and use higher reflective measuring surface. Contact HOKUYO if the error persist after checking the measurement setup. |
| 256 | @E256 | Received signal too high | Check measurement setup and use lower reflective measuring surface. Contact HOKUYO if the error persist after checking the measurement setup. |
| 257 | @E257 | Background light too strong | Reduce background lights (sunlight or other strong light source) or replace measuring target. |
| 258 | @E258 | Power supply voltage is too high | Check the supply voltage against the device specification. |
| 259 | @E259 | Power supply voltage is too low | Check the supply voltage against the device specification. |
| 260 | @E260 | Signal too unstable for a distance measurement | Check measurement setup and use stable measuring surface |
| Not listed | | Please contact HOKUYO | |

- 1) To calculate the error code out of the SSI error data (see 6.3.10 Set/Get configuration of RS-422/SSI), do the calculation as follows:
 Error code = SSI error data +200.

Before contacting HOKUYO, please prepare information about the following subjects. This will help to find out the cause of a failure / error.

- Device type and serial number
- Error code / codes and status LED's
- Short description of measuring setup (Used interface, configuration, measuring target, measurement conditions, etc.)
- Short description of the device behavior before, during and after error

| | | | | |
|-------|---|-------------|-----------|---------|
| Title | PGL-050W3/180W3 Technical Reference Manual | Drawing No. | C-41-2607 | 40 / 45 |
|-------|---|-------------|-----------|---------|



7. Safety instructions

The following instructions are to enable the person responsible for the PGL-Series laser distance sensor, and the user of the instrument, to anticipate and avoid operational hazards.

The PGL-Series sensor is made to be integrated into technical systems. Basic technical training is therefore essential. This device may only be operated by trained personnel.

The person responsible for the instrument must ensure that all users understand these instructions and adhere to them.

If the PGL-Series sensor is part of a system, the manufacturer of such a system is responsible for all safety-related issues, such as the manual, labeling and instruction.

7.1 Use of the instrument

Permitted use:

The permitted use of the device is: measuring distances.

Prohibited use:

Use of the instrument without instruction

Use outside the stated limits

Deactivation of safety systems and removal of explanatory and hazard labels

Opening of the equipment, except to open the cover for access to the screw terminal

Carrying out modification or conversion of the product

Operation after failure in operation

Use of accessories from other manufacturers without the express approval of HOKUYO

Aiming directly into the sun

Deliberate dazzling of third parties; also in the dark

Inadequate safeguards at the surveying location (e.g. when measuring on roads, etc.)



Prohibited use can lead to injury, malfunction, and material damage. It is the duty of the person responsible for the instrument to inform the user about hazards and how to counteract them. The PGL-Series devices must not be operated until the user has been adequately instructed.

7.2 Limits to use

See chapter 2 Technical data.

Environment:

Suitable for use in an atmosphere appropriate for permanent human habitation. The device must not be used in environments such as but not limited to:

- Aggressive vapor or liquids (salt, acid, poison, etc.)
- Snow and rain
- Radiation (radioactive, heat, etc.)
- Explosive atmosphere

| | | | | |
|-------|---|----------------|-----------|---------|
| Title | PGL-050W3/180W3 Technical Reference Manual | Drawing No. | C-41-2607 | 41 / 45 |
|-------|---|----------------|-----------|---------|



7.3 Areas of responsibility

Hokuyo is responsible for supplying the product, including the Technical Reference Manual and original accessories, in a completely safe condition.

Responsibilities of the person in charge of the instrument:

The person in charge of the instrument has the following duties:

To understand the safety instructions for the product and the instructions in the Technical Reference Manual.

To be familiar with local safety regulations relating to accident prevention.

To inform Hokuyo immediately if the equipment becomes unsafe.



The person responsible for the instrument must ensure that the equipment is used in accordance with the instructions. This person is also accountable for the deployment of personnel and for their training and for the safety of the equipment when in use.

7.4 Hazards in use



The absence of instruction, or the inadequate provision of instruction, can lead to incorrect or prohibited use, and can give rise to accidents with far-reaching personal, material and environmental consequences.

Precautions

All users must follow the safety instructions given by the manufacturer and the directions of the person responsible for the instrument.



Beware of erroneous distance measurements if the instrument is defective or if it has been dropped or has been misused or modified.

Precautions

Carry out periodic test measurements, particularly after the instrument has been subject to abnormal use, and before, during and after important measurements. Make sure the PGL-Series device optics are kept clean.



If labels are hidden when the PGL-Series device is installed, this could lead to dangerous situations.

Precautions

Always ensure the visibility of PGL-Series device labels at all times or add labels in accordance with the local safety regulations.



When using the instrument for distance measurements or for positioning moving objects (e.g. cranes, building equipment, platforms, etc.) unforeseen events (e.g. breaking the laser beam) may cause erroneous measurements.

Precautions

Only use this product as a measuring sensor, not as a control device. The system must be configured and operated in such a way that no damage will occur in the event of an erroneous measurement, malfunction of the device or power failure due to installed safety measures (e.g. safety limit switch).



Operate the equipment appropriately in accordance with the regulations in force. Always prevent access to the equipment by unauthorized personnel.

Precautions

Do not point the telescope directly at the sun.



Be careful when pointing a telescope towards the sun, because the telescope functions as a magnifying glass and can injure eyes and/or cause damage inside the PGL-Series device.

| | | | | |
|-------|---|----------------|-----------|---------|
| Title | PGL-050W3/180W3 Technical Reference Manual | Drawing No. | C-41-2607 | 42 / 45 |
|-------|---|----------------|-----------|---------|



7.5 Laser classification

The PGL-Series laser distance sensor produces a visible laser beam, which emerges from the front of the instrument.

It is a Class 2 laser product in accordance with:

IEC/EN 60825-1:2014 "Radiation safety of laser products"

It is a Class II laser product in accordance with:

FDA 21 CFR 1040.10 and Laser Notice 50 (US Department of Health and Human Service, Code of Federal Regulations)

Laser Class 2/II products

Do not stare into the laser beam or direct it towards other people unnecessarily. Eye protection is normally afforded by aversion responses including the blink reflex.



Looking directly into the beam with optical aids (binoculars, telescopes) can be hazardous.

Precautions

Do not look into the laser beam. Make sure the laser is aimed above or below eye level. (particularly with fixed installations, in machines, etc.).



Looking into the laser beam may be hazardous to the eyes.

7.6 Electromagnetic compatibility (EMC)

The term "electromagnetic compatibility" is taken to mean the capability of the PGL-Series laser distance sensor to function smoothly in an environment where electromagnetic radiation and electrostatic discharges are present, and without causing electromagnetic interference to other equipment.



Electromagnetic radiation can cause interference in other equipment. Although the PGL-Series device meets the strict regulations and standards that are in force in this respect, HOKUYO cannot completely exclude the possibility that interference may be caused to other equipment.

7.7 Producer standards

Hokuyo hereby certifies that the product has been tested and complies with the specifications as stated in this "Technical Reference Manual". The test equipment used is in compliance with national and international standards. This is established by our Quality Management System. Further, the PGL-Series devices are produced in compliance with 2011/65/EU «RoHS».

7.8 Disposal



This symbol on the product or on its packaging indicates that this product must not be disposed of with your other household waste. Instead, it is your responsibility to dispose of the equipment by handing it over to a designated collection point for the recycling of waste electrical and electronic equipment. The separate collection and recycling of your waste equipment at the time of disposal will help to conserve natural resources and ensure that it is recycled in a manner that protects human health and the environment. For more information about where you can drop off your waste equipment for recycling, please contact your local city office, your household waste disposal service or the dealer where you purchased the product. In countries in which HOKUYO has no subsidiaries, HOKUYO delegates the duty for the disposal in compliance with 2012/19/EU«WEEE» to the local dealer or to the customer, if no dealer is present.

| | | | | |
|-------|---|----------------|-----------|---------|
| Title | PGL-050W3/180W3 Technical Reference Manual | Drawing No. | C-41-2607 | 43 / 45 |
|-------|---|----------------|-----------|---------|



7.9 Labeling

The labeling of the PGL-Series sensor is shown in Figure 7-1. The existing device type labels and the product label are shown in Figure 7-2 and Figure 7-3..



Figure 7-1: Labeling of the PGL-Series devices (Label position and view)

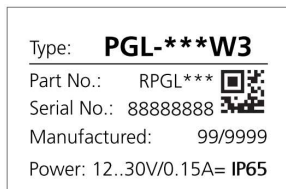

Figure7-2: PGL-Series device type labels

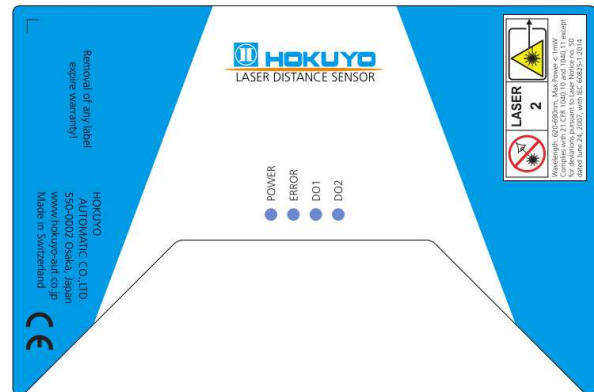

Figure7-3: PGL-Series product label

7.10 Laser Specification

| | |
|-------------------------------------|------------------------------|
| Standard applied | IEC/EN 60825-1:2014 |
| Emitted wavelength | 620~690 nm (typical 655 nm) |
| Beam divergence | 0.16 x 0.6 mrad |
| Pulse duration | 0.2~0.8 x 10 ⁻⁹ s |
| Max. radiant power | 1 mW |
| Laser power measurement uncertainty | ±5% |

7.11 Maintenance

The PGL-Series laser distance sensor is almost maintenance free. The only thing you have to do is to clean the surfaces of the lenses.



Look after the surfaces of the lenses with same care that you would apply to spectacles, cameras and field glasses. Clean the optical parts (small laser output glass and the round lens) only with a clean soft glasses cleaning cloth and avoid scratching of the optical parts. All other cleanser or resolvent are not allowed.

| | | | | |
|-------|---|-------------|-----------|-------|
| Title | PGL-050W3/180W3 Technical Reference Manual | Drawing No. | C-41-2607 | 44/45 |
|-------|---|-------------|-----------|-------|

7.12 Service

If you need to service the device, please contact Hokuyo for instructions.



The warranty is void if the device is opened except the cover of the screw terminal. Removing the label is also understood as opening.

8. Glossary

| | |
|-------|--|
| ASCII | American Standard Code for Information Interchange (ASCII) |
| ESD | Electrostatic Discharge |
| EMC | Electromagnetic Compatibility |
| PLC | Programmable Logic Controller (e.g. Siemens S7) |
| SSI | Serial Synchronous Interface (SSI) |

Important Notice

Hokuyo reserves the right to make corrections, modifications, enhancements, improvements and other changes to its products, documentation and services at any time and to discontinue any product or service without notice. We try to give our best possible effort to provide you with perfect documents, but we can not guarantee for incorrect information. Customers should obtain the latest relevant information before placing orders and should verify that such information is up to date and complete. All products are sold subject to Hokuyo terms and conditions of sale supplied at the time of order acknowledgment.

© Copyright by Hokuyo

Hokuyo Automatic Co., Ltd Tel. +81 6 6441 2213
Higobashi Union Building Fax +81 6 6441 2203
1-9-6 Edobori, Nishi-ku,
Osaka 550-0002 Japan www.hokuyo-aut.jp

| | | | | |
|-------|---|----------------|-----------|---------|
| Title | PGL-050W3/180W3 Technical Reference Manual | Drawing No. | C-41-2607 | 45 / 45 |
|-------|---|----------------|-----------|---------|

