

Date : 2023.12.11

Safety Laser Scanner UAM-05LPA-T301C Specification



RoHS

Approved by	Checked by	Drawn by	Designed by	Title	Safety Laser Scanner UAM-05LPA-T301C Specification	
Kamitani	Higashi	Kobayashi	Kobayashi		Drawing No.	C-62-00056

1.Applicable directives and standards

UAM is certified by TUV SUD Product Service GmbH and UL/c-UL, FDA (CDRH) as a safety sensor defined in EU Machine Directive (2006/42/EC).

Table1-1 Applicable directives and standards

Certification authority	Directives/Standard	Details		
TUV SUD	EU directives	Machinery Directive: Directive 2006/42/EC		
		EMC Directive: Directive 2014/30/EU		
		RoHS Directive : Directive2011/65/EU		
	EN standards IEC standards ISO standards	IEC 61496-1:2020 EN 61496-1:2020	Type 3	
		IEC 61496-3:2018	Type 3	
		IEC 61508 Part1-7:2010	SIL2	
		EN62061:2005/A2:2015	SIL2	
EN ISO13849-1:2015		Category 3, PLd		
IEC60825-1:2014	Safety of laser products Class 1			
UL/c-UL	UL stanarad IEC standard ISO standard CSA standard	UL 508:2010	-	
		ANSI/UL 1998:2013	-	
		IEC 61496-1:2020	Type 3	
		IEC 61496-3:2018	Type 3	
		IEC61508 Part1-7:2010	SIL 2	
		ISO 13849-1:2015	Category 3,PLd	
		CSA C22.2 No14-13:2013	-	
FDA (CDRH)		21 CFR Part 1040.10 and 1040.11	Safety of laser products Class 1	

Title	Safety Laser Scanner UAM-05LPA-T301C Specification	Drawing No.	C-62-00056	2 / 44
-------	---	----------------	------------	--------

2. Specification

Table 2-1 UAM-05LPA specification

Subject	Specifications	
Model	UAM-05LPA-T301C	
Detection property	Protection Range	Max: 5m
	Warning Range	Max: 30m (Non-safety) *1
	Distance tolerance *2	+100 mm
	Detection capability	From Black-Reflector Sheet (1.8%) to Retro-Reflector Sheet
	Angular Range	270 °
	Minimum Detectable Width	φ30 mm (Max: 1.8m) φ40 mm (Max: 2.5m) φ50 mm (Max: 3.0 m) φ70 mm/150mm (Max: 5.0 m)
	Scan Frequency	30ms (Rotational Speed: 2000 rpm)
	Area pattern Δ	Max 32 patterns(pair input mode) Max 128 patterns(Fixed input mode/Encoder mode)
	Response time	OFF 60 ms~2010 ms ON 270 ms~2010 ms
Optics	Element	Pulsed Laser Diode
	Wave Length	905 nm
	Safety Class	Laser Class 1
Type	Type 3 (IEC61496-1, IEC61496-3)	
Functional Safety	SIL 2 (Type B, HFT=1) (IEC61508)	
PFH _d	8.1×10 ⁻⁸ (T1=20 year) : When master slave function is not in use. 1.6×10 ⁻⁷ (T1=20 year) : When master slave function is in use.	
Housing	Size	80mm (W)×80mm (D)×95mm (H) (without cable)
	Weight	0.5Kg
	Protection	IP65
	Case Material	Body: Aluminum Optical Window: Polycarbonate
	Connection Cable	Waterproof connector : 0.3m
Power supply	DC 24V ±10%: when operation using converter power supply DC 24V -30%/+20%: when operation using battery	
Supply current	Normal (without load)	6W
	Max. (with load)	50W

*1.Distance when reflectance of the object is 90% or above.

*2. Additional distance of 200mm is needed when the UAM is working under high reflective background.

Title	Safety Laser Scanner UAM-05LPA-T301C Specification	Drawing No.	C-62-00056	3 / 44
-------	---	----------------	------------	--------

Subject	Specifications	
Output	OSSD 1/2 (Safety)	Output type (High side SW)
		Output current:(Max:500mA) *3
		Leak current (Max:1mA)
		AWG 26
		Load tolerance (L/R=25ms, C=1μF)
	OSSD3/4 (Safety)/ WARNING 1/ 2 (Non-Safety)	Output type (High side SW)
		Output current:(Max:250mA) *3
		Leak current (Max:1mA)
		AWG 28
RES_REQ 1, RES_REQ 2, MUT_OUT 1, MUT_OUT 2, AUX_OUT1, AUX_OUT2	Load tolerance (L/R=25ms, C=1μF)	
	Output types (PNP Transistor)	
	Output current (Max: 200mA)	
	Leak current (Max: 1mA)	
Input	Area pattern 32 (5 Inputs x 2 Channels) EDM1, EDM2, MUTING1, MUTING2, MUTING3, MUTING4, OVERRIDE1, OVERRIDE2, RESET1, RESET2	Input Impedance 4.7 kΩ
		AWG 28
	ENC1_A/B, ENC2_A/B, ENC3_A/B, ENC4_A/B	Input Impedance 4.7 kΩ
Interface	Configuration	USB2.0 (USB micro type-B connector)
		RS-485
		Ethernet 100BASE-TX (Water proof connector)
Communication Data	Measurement Error(Distance) *4	±20mm(TYP)
	Max Range(Distance)	40m
Angular Error*4	Vertical Plane	±1°(Beam divergence is excluded)
	Horizontal Plane	±0.3°(Beam divergence is excluded)
Environmental resistance	Temperature	-10°C to +50°C (No freezing)
	Storage Temperature	-25°C to +70°C (No freezing)
	Humidity	95% RH with no condensation
	Storage Humidity	95% RH with no condensation
	Surrounding Intensity *5	Less than 1500 lx
	Vibration	Frequency range: 10~55 Hz Sweep rate: 1octave/min Amplitude: 0.35 mm ±0.05 mm
	Bump	Acceleration: 98m/s ² (10G) Pulse duration: 16 ms
	Outdoor Operation	Not permitted
	Altitude	Below 2000m

*3.Total current supply of OSSD output and Warning output should be below 1.0A.

*4.Reference data measured at the manufacturer's facility.

*5.When the light sources are located at ≥5° from the detection plane of UAM.

Title	Safety Laser Scanner UAM-05LPA-T301C Specification	Drawing No.	C-62-00056	4 / 44
-------	---	-------------	------------	--------

scan Angle Error (Reference data)

Horizontal and vertical angular error of the optics with reference to the UAM's mechanical axes are $\pm 0.3^\circ$ and $\pm 1^\circ$ respectively (figure below). Mount the device appropriately if it is necessary to strictly limit the detection range.

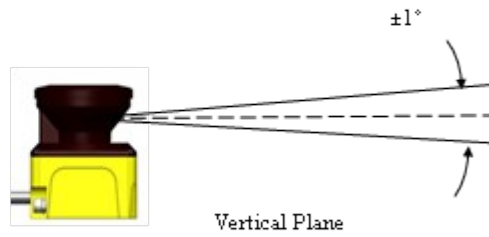
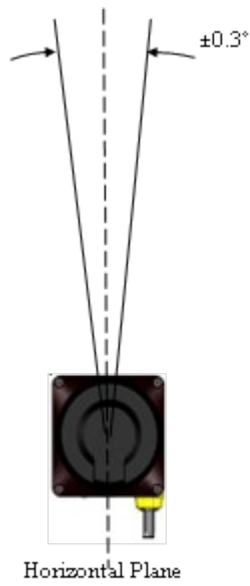

Title	Safety Laser Scanner UAM-05LPA-T301C Specification	Drawing No.	C-62-00056	5 / 44
-------	---	----------------	------------	--------

3. Components of UAM-05LPA

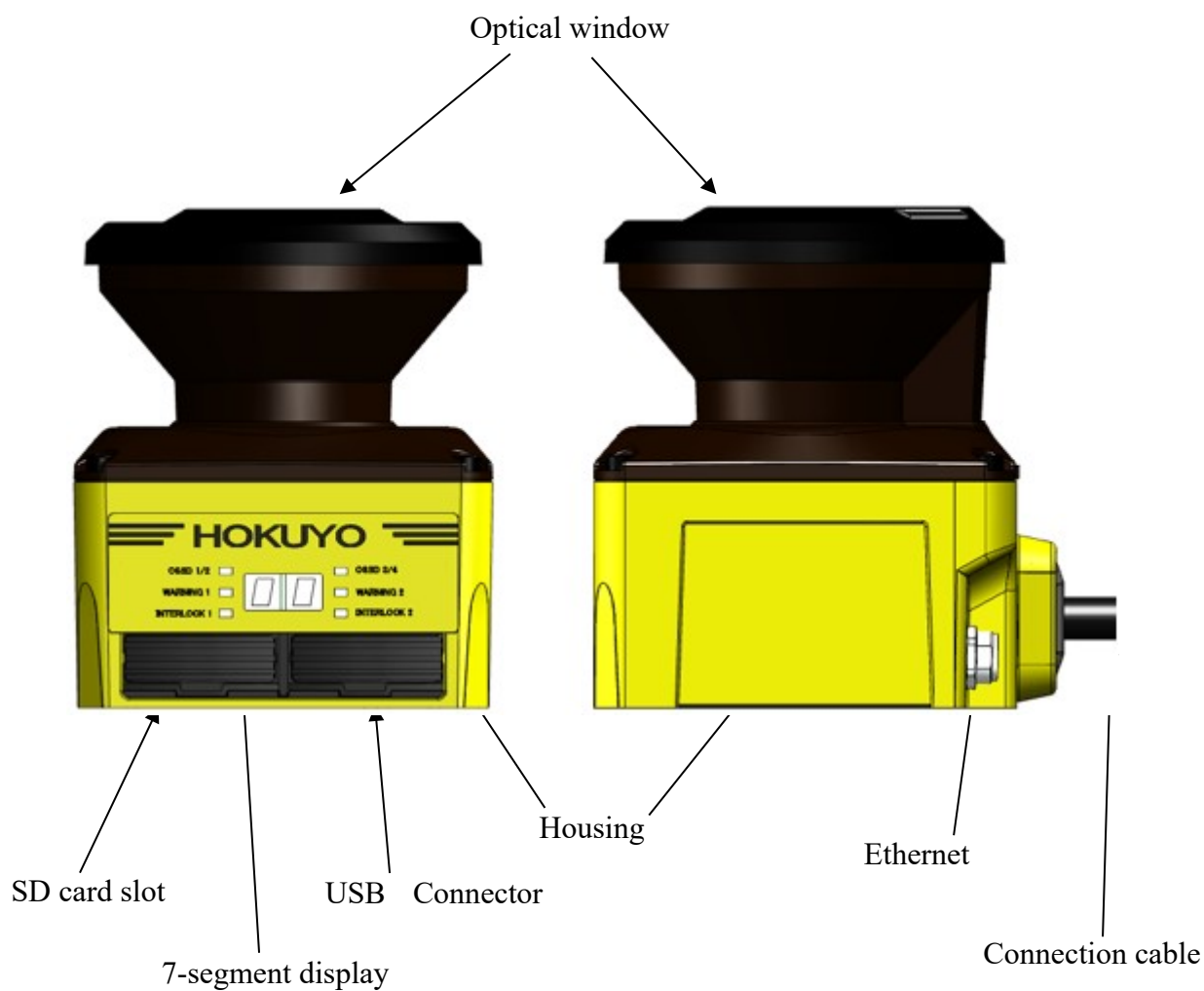

Figure3-1 UAM-05LPA-T301C Components

Title	Safety Laser Scanner UAM-05LPA-T301C Specification	Drawing No.	C-62-00056	6 / 44
-------	---	----------------	------------	--------

4. Function

4.1 Scanning area

Scanning area of UAM consists of protection zone and warning zones. Maximum 32 sets of area can be configured. Further, two combinations for protection and warning zones can be selected for the operation.

Combination 1: Protection zone, Warning zone 1 and Warning zone 2

Combination 2: 2 Protection zones (Dual Protection)

In dual protection mode, two protection areas can be configured but it is not possible to configure the warning zones. Protection and warning zones can be configured by using UAM Project Designer. Refer to User's Manual for configuration details.

4.1.1 Protection zone

Protection zone is safety-critical and directly connected to the OSSD signal. When an obstacle is detected in the protection zone, UAM will switch the OSSD to OFF-state (which should trigger a switch to stop a machine or AGV). For mobile applications, the OSSD signal can be used as the emergency stop signal. Figure 4-1 and 4-2 show the examples of protection zone configured using manual mode and teaching mode respectively. User can configure these zones accordingly to ensure hazardous area is completely protected.

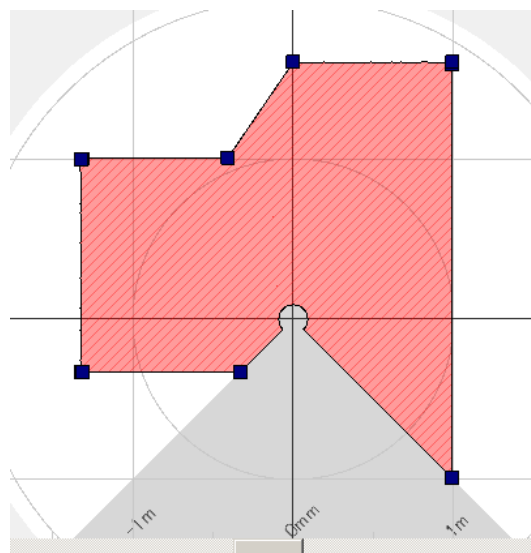

Figure 4-1 Protection zone configured using manual mode

Title	Safety Laser Scanner UAM-05LPA-T301C Specification	Drawing No.	C-62-00056	7 / 44
-------	---	----------------	------------	--------

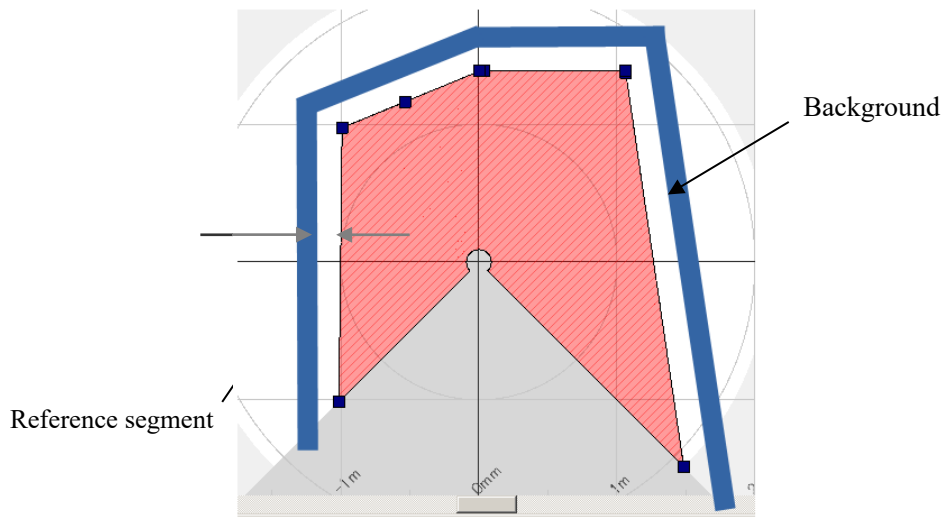

Figure 4-2 Protection zone configured using teaching mode

In dual protection mode, two protection zones can be configured independently. UAM will monitor these zones simultaneously. OSSD1 and OSSD2 are dedicated to protection zone1 and OSSD3 and OSSD4 are dedicated to protection zone2.

Figure 4-3 shows an example of the dual protection zone configuration. Warning zones cannot be configured in dual protection mode.

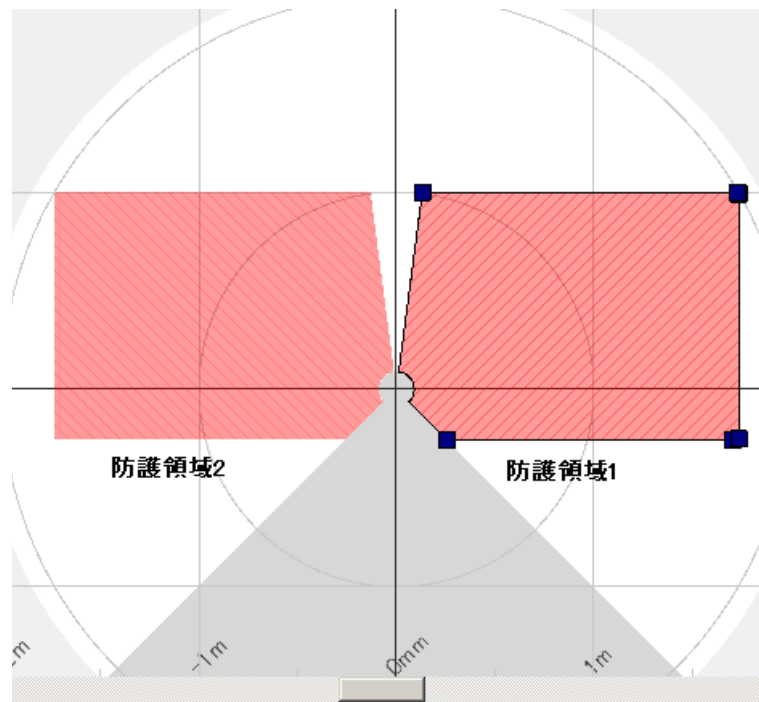

Figure 4-3 Example of Dual protection zone configuration

Title	Safety Laser Scanner UAM-05LPA-T301C Specification	Drawing No.	C-62-00056	8 / 44
-------	---	----------------	------------	--------

4.1.2 Warning zone

Warning zones are non-safety zones and are connected to Warning1 and Warning2 outputs. When the obstacle is detected in the warning zones, UAM will switch the respective warning signal from ON-state to OFF-state.

Warning signals can be used as an alert signal to avoid human beings or objects from approaching near the protection zone. For mobile applications, warning signals can be used for reducing the speed of automatic guided vehicle (AGV) to avoid collision. Figure 4-4 shows an example of warning zone configuration.

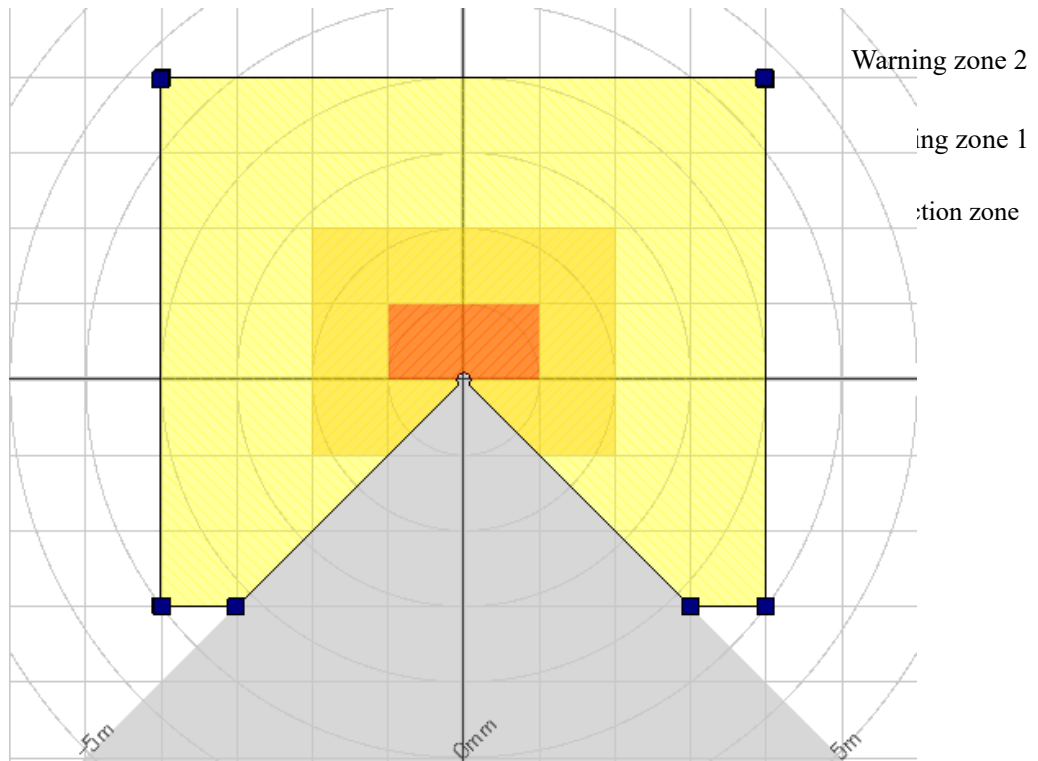

Figure 4-4 Warning zones

Title	Safety Laser Scanner UAM-05LPA-T301C Specification	Drawing No.	C-62-00056	9 / 44
-------	---	----------------	------------	--------

4.2 OSSD

OSSD is safety-related signal. When humans or objects are detected in the protection zone, the OSSD signal will switch to OFF state from ON-state. OSSD signal has the self-diagnostic function which tests the signal periodically by switching it to OFF state for a brief period. Signal is continuously switched to OFF-state when an error is detected during the diagnostic.

Output states of OSSD1 and OSSD2 signal are identical. Both signals should be connected to the safety related machines or control system to fulfill the required safety level. If OSSD3 and OSSD4 are used they must be connected in the same manner.

4.2.1 Self-diagnostic function of OSSD

Self-diagnostic is a function to detect the malfunction in the output circuit by switching OFF the OSSD1 to OSSD4 for an interval of 300 μ s. Therefore, safety-relay or power converter used must not response to this diagnostic function. Figure 4-5 below shows the timing chart of the self diagnostic function of the OSSD during dual protection mode.

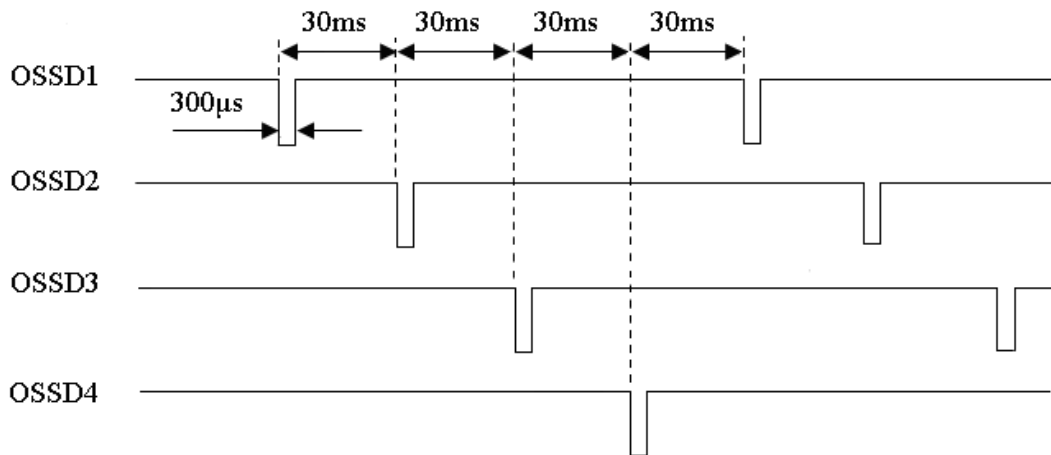

Figure 4-5 Timing chart of the OSSD's self-diagnostic function

In single protection mode, self-diagnostic function is done for OSSD1 and OSSD2 only.

Title	Safety Laser Scanner UAM-05LPA-T301C Specification	Drawing No.	C-62-00056	10 / 44
-------	---	----------------	------------	---------

4.3 Interlock function

Interlock is a function to prevent automatic restart of the OSSD signal switching from OFF-state to ON-state. Automatic restart, manual restart and manual start interlock functions are configurable using the UAM Project Designer.

4.3.1 Automatic restart

UAM will restart automatically when interlock function is disabled or only the start interlock function is enabled. When obstacle from the protection zone is removed, OSSD signals switch from OFF-state to ON-state automatically. OSSD response times for ON and OFF states are configurable. However, if UAM is in the lockout state due to error, OSSDs will remain in OFF-state even if the interlock function is disabled.

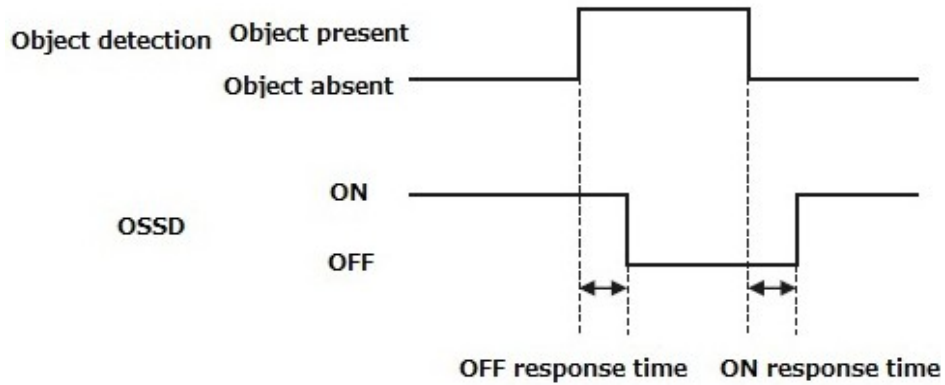

Figure 4-6 Timing chart of automatic restart

Title	Safety Laser Scanner UAM-05LPA-T301C Specification	Drawing No.	C-62-00056	11 / 44
-------	---	----------------	------------	---------

4.3.2 Manual restart (Interlock enabled)

UAM operates in manual restart mode when interlock function is set to manual mode. The OSSD signal switches from ON-state to OFF-state, if UAM detects any obstacle within the protection zone or detects any system error. In this mode, even if the detected obstacles or system error is removed, OSSD signals will remain in OFF-state. An external reset input signal is required to release the interlock which allows the UAM to switch to normal operation.

UAM will resume normal operation only after confirming the reset signal (RESET). The duration of the reset signal should be more than 500ms. Figure 4-7 shows the timing chart of the manual restart. After reset signal is confirmed, the OSSD signal will switch to ON-state after the lapse of the configured delay time. . If OSSD's OFF-state is due to an internal fault, it will remain in OFF-state even when reset signal is provided. Reset delay is configurable in the range of 1s to 6s.

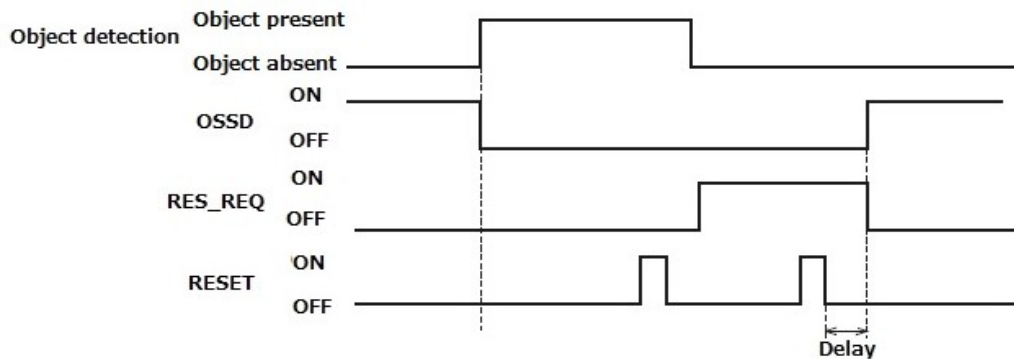

4.3.3 Manual start (Interlock enabled)

Start interlock is a function which keeps the OSSD in OFF-state during the start-up until an external reset input is applied. Start interlock setting has only manual mode. The RES_REQ signal switches to ON-state after the UAM completes initial routines and ready to accept the RESET input. When RESET input is applied, OSSD will switch to ON state if no object is detected in the protection zone. The duration of the reset input should be more than 500ms. Figure 4-8 shows the sequence of start interlock. Delay can be configured in the range of 1s to 6s.

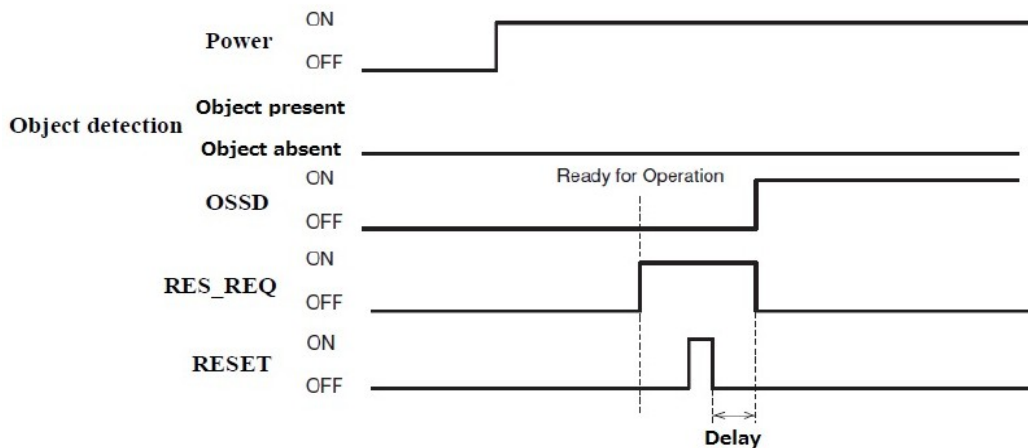

Title	Safety Laser Scanner UAM-05LPA-T301C Specification	Drawing No.	C-62-00056	12 / 44
-------	---	----------------	------------	---------

4.4 External device monitoring (EDM) function

EDM is a function that monitors the state of the input signal from the controlled machine or automated guided vehicle (AGV). EDM is configured using the UAM project designer. When EDM function is enabled, any fault detected in EDM signal will switch the OSSD signal to OFF-state. Logic of EDM signal should be always inverse of the OSSD signal. EDM input signal ON/OFF delay is configurable to match the user's system. Figure 4-9 and 4-10 below shows the EDM circuit and EDM timing chart respectively.

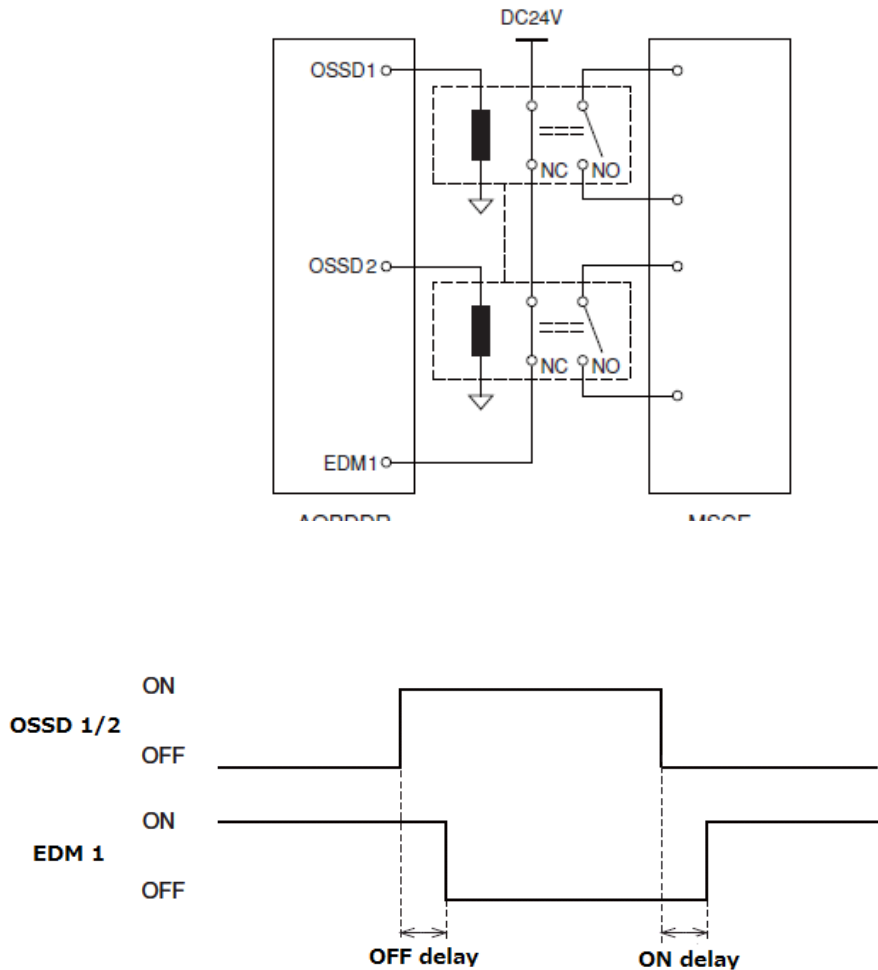

Figure 4-10 EDM timing chart

In dual protection mode, EDM2 circuit and timing chart for OSSD3 and OSSD4 are same as above.

Title	Safety Laser Scanner UAM-05LPA-T301C Specification	Drawing No.	C-62-00056	13 / 44
-------	---	----------------	------------	---------

4.5 Muting function

Muting function temporarily suspends the safety function in the configured zone of UAM when the specified conditions are fulfilled. In the muting state OSSD remains in the ON-state even when an object is detected in the configured muting zone. Two independent hard wired input signals are provided to start and end the muting function. Muting zone is configured using the UAM project designer. When muting inputs fulfill the muting start conditions, UAM will suspend the safety function within 60ms and resume the safety function if they fulfill the muting stop conditions.

4.5.1 Muting start condition

Muting function will start when the following conditions are fulfilled:

- a) There are no objects in the protection zone and the OSSD is in ON-state.
- b) The two independent hard wired muting input signals are switched to ON state in the predefined sequence within the pre-set time interval. However, the switching interval between two input signals should not be 0 (Refer to figure 4-11).

The following configurations are necessary for the muting function. User can configure these by using the UAM project designer.

- Muting inputs sequence
 - ▶ Muting 1 → Muting 2
 - ▶ Muting 2 → Muting 1
- Time interval between two inputs (T1)
 - ▶ 1second
 - ▶ 3seconds
 - ▶ 5seconds
 - ▶ 10seconds

When using muting function in dual protection mode, Muting 3 and Muting 4 are configured in the similar way.

Title	Safety Laser Scanner UAM-05LPA-T301C Specification	Drawing No.	C-62-00056	14 / 44
-------	---	----------------	------------	---------

4.5.2 Muting stop condition

Muting function will stop when any one of the condition below is fulfilled:

- One of the muting inputs switches to OFF-state.
- When the predefined (preset) maximum muting time T_2 exceeds (1 minute and above) (Figure 4-11).
- Objects are detected in the protection zone which is not covered by the muting zone.
- Error is detected by the self-diagnostics function.
- During muting state when the area is switched to other area.

Figure 4-11 shows the muting sequence.

- Maximum muting period (T_2)
Maximum muting period can be selected from one of these values
 - ▶ 1 minute
 - ▶ 6 minutes
 - ▶ 12 minutes
 - ▶ Unlimited

When using the muting function in dual protection mode, Muting 3 and Muting 4 are configured in the similar way. Same applies for muting input sequence, time interval between inputs and maximum muting period.

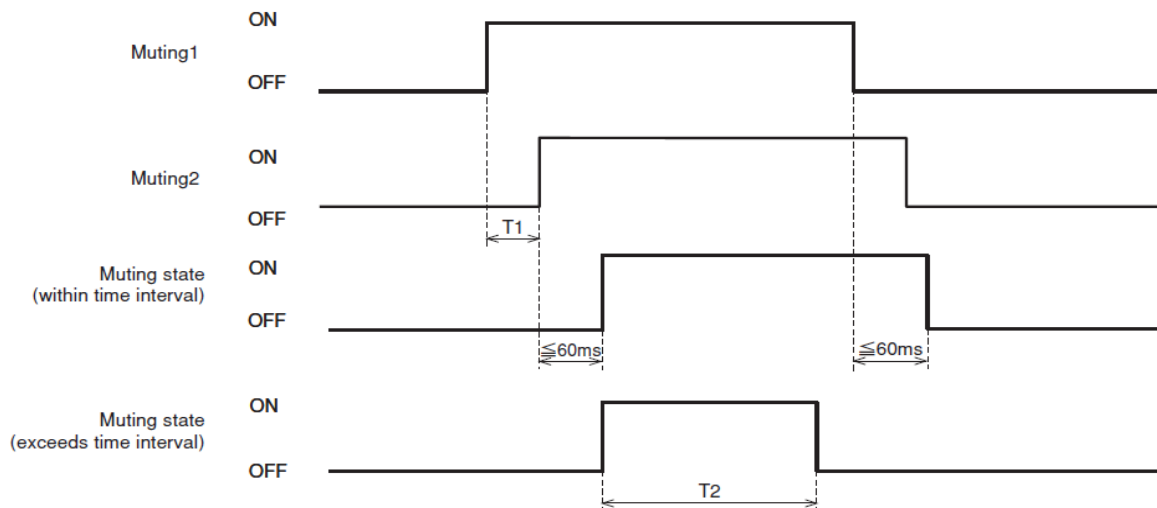

Title	Safety Laser Scanner UAM-05LPA-T301C Specification	Drawing No.	C-62-00056	15 / 44
-------	---	----------------	------------	---------

4.5.3 Muting override function

Muting override is a function to recover UAM when the OSSD is switched to OFF state due to muting related errors by temporarily suspending the safety function. Override function is active when the override input (OVERRIDE 1/2) and the reset input (RESET 1/2) are switched in a sequence. Figure 4-12 shows the override sequence.

- Override start conditions
 - ▶ At least one of the muting inputs is in ON-state.
 - ▶ Object is present in the protection zone.
 - ▶ Time interval between override input and reset input is within 0.03s to 1s (T3).
- Override stop conditions
 - ▶ Both muting inputs are in OFF-state.
 - ▶ Override input or reset input is in OFF-state.
 - ▶ When predefined maximum override time T4 exceeds.
 - ▶ Error is detected by self-diagnostic function of the UAM.
 - ▶ During override state when area is switched to the other area.
- Maximum override period (T4)

Maximum override period can be selected from one of these values

 - ▶ 1 minute
 - ▶ 6 minutes
 - ▶ 12 minutes

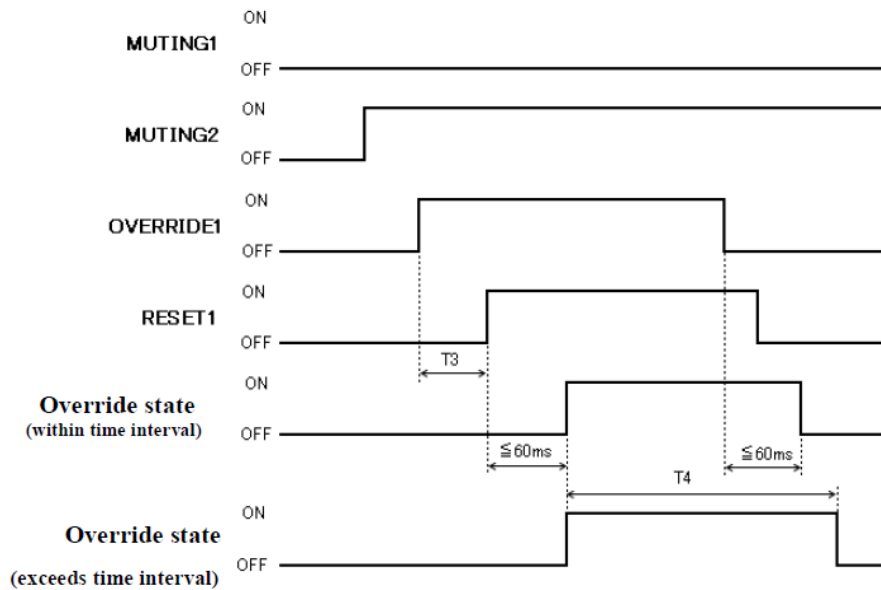

When using muting override in dual protection mode, Muting 3, Muting 4, Override input 2 and Reset input 2 are configured in the similar way.

Title	Safety Laser Scanner UAM-05LPA-T301C Specification	Drawing No.	C-62-00056	16 / 44
-------	---	----------------	------------	---------

4.6 Reference monitoring function

Reference monitoring is a function to monitor the displacement of the UAM or the structure used as reference boundary.

4.6.1 Area protection

An example of reference monitor function used for area protection is shown in figure 4-13. If reference segments are configured on moveable objects (example: door) the OSSD will switch to OFF-state when the door position is changed.

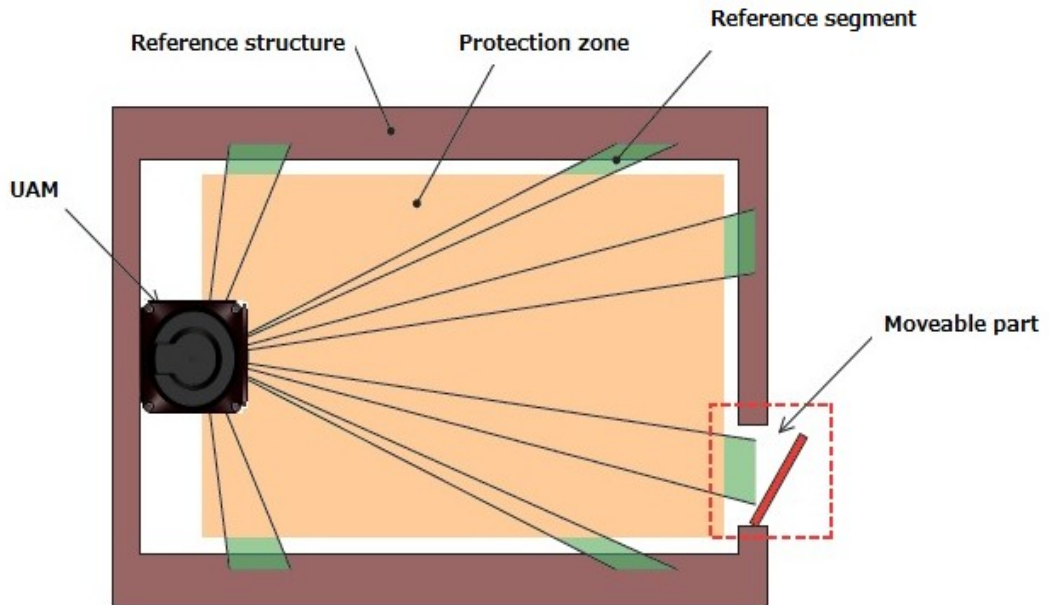

Figure 4-13 Top view of the area protection using reference monitor function

Title	Safety Laser Scanner UAM-05LPA-T301C Specification	Drawing No.	C-62-00056	17 / 44
-------	---	----------------	------------	---------

4.6.2 Access protection

An example of reference monitor function used for access protection is shown in figure 4-14(a), (b). Reference segments should be configured on each surface for displacement detection. Reference segments should be configured such that displacement can be easily detected. The OSSD will switch to OFF-state when access penetration is detected, and also if the distance between UAM and the reference structure changes. This function is compulsory for vertical applications.

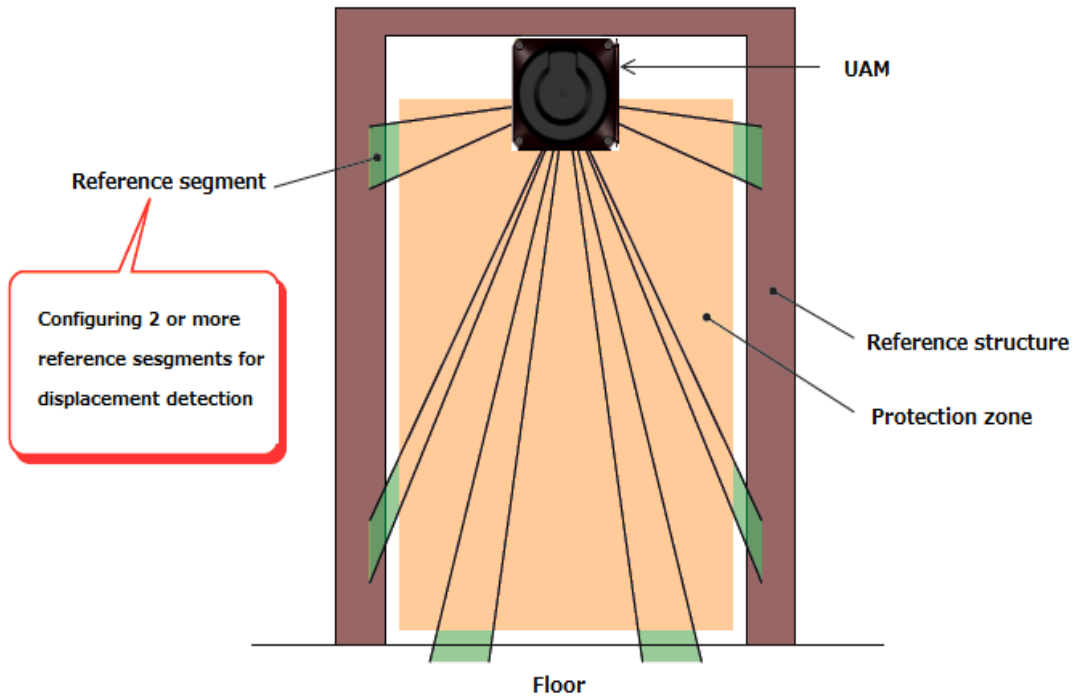

Figure 4-14(a) Front view of the access detection using reference monitor function

Title	Safety Laser Scanner UAM-05LPA-T301C Specification	Drawing No.	C-62-00056	18 / 44
-------	---	----------------	------------	---------

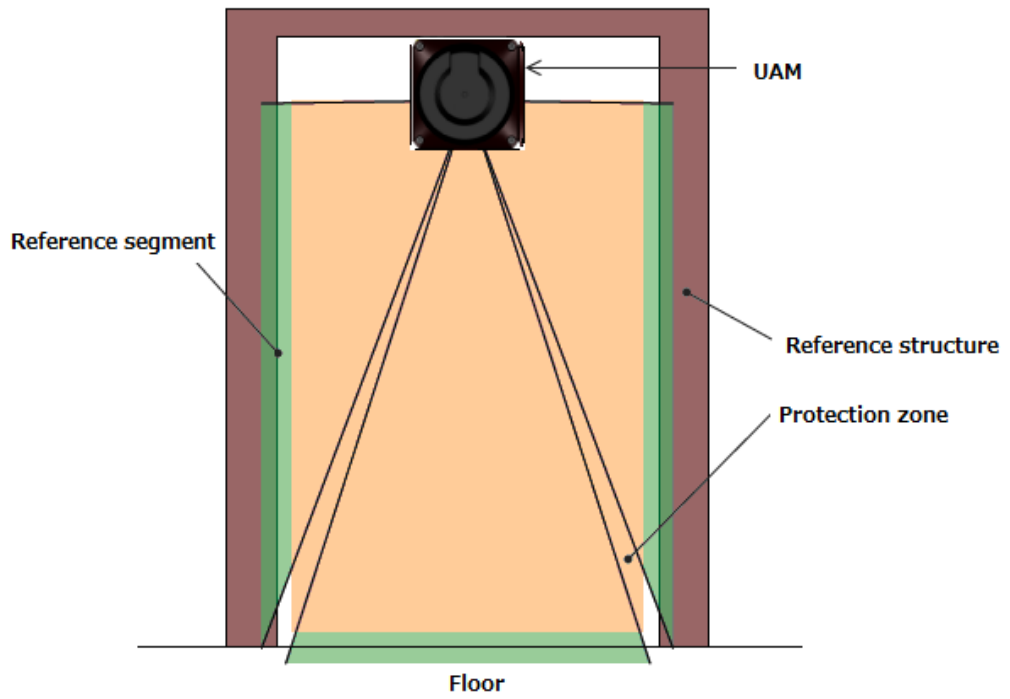

Figure 4-14(b) Front view of the access detection using reference monitor function

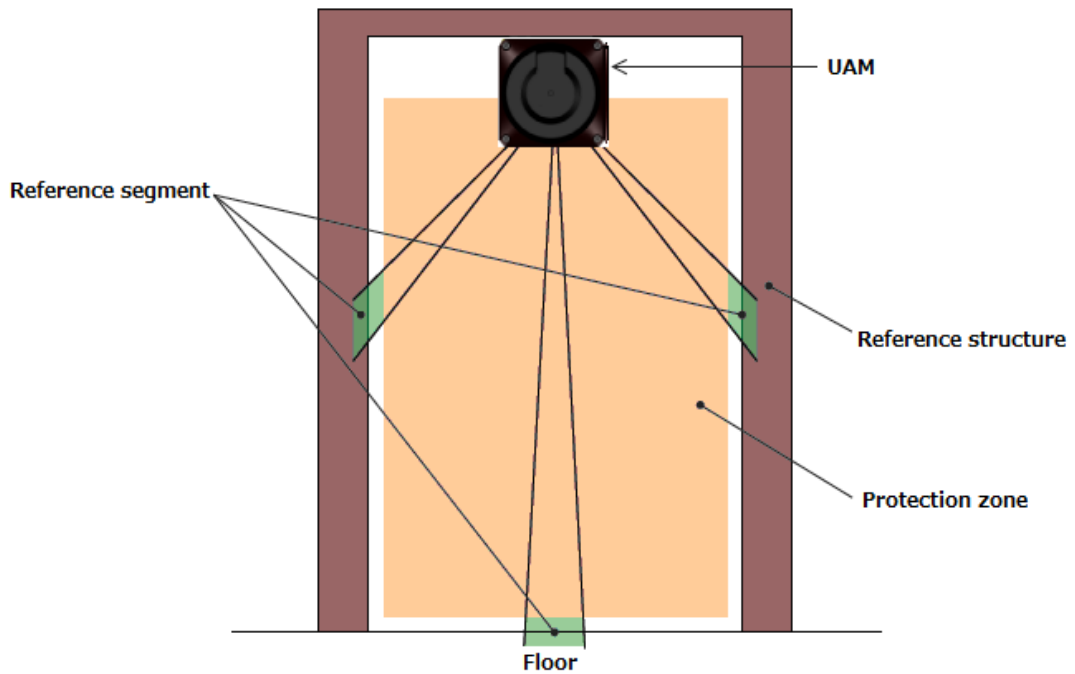

Figure 4-14(c) Incorrect configuration of reference segment

Title	Safety Laser Scanner UAM-05LPA-T301C Specification	Drawing No.	C-62-00056	19 / 44
-------	---	----------------	------------	---------

4.7 Area sequence function

Area sequence is a function to monitor sequences of area switching. When this function is activated, OSSD signal will switch to OFF-state if the switching pattern is other than the configured sequence. This function prevents the machine to operate with random protection zone.

From each area, switching selection to maximum 127 other areas is possible when configuring the area sequence. And, it is necessary to specify 1 or more areas to avoid error.

<Area switching sequence>

When area sequence is disabled, UAM can switch from an area to any other areas (Figure 4-15(a)) whereas it can only switch to specified areas if area sequence is enabled. (Figure 4-15(b)).

Area sequence function is recommended for control systems where switching area sequences can be configured.

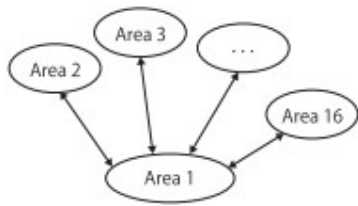

Figure 4-15(a) Operation without area sequence

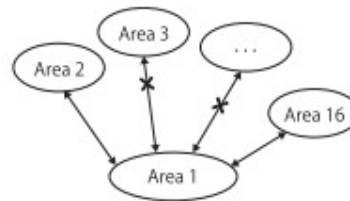

Figure4-15(b) Operation with area sequence

Title	Safety Laser Scanner UAM-05LPA-T301C Specification	Drawing No.	C-62-00056	20 / 44
-------	---	----------------	------------	---------

4.8 Response time

Response times of OSSD signal (Figure 4-16), OFF response time (Default 60ms) and ON response time (Default 270ms) are configurable individually for each area using the UAM project designer. Response time of the Warning 1 and Warning 2 will be same as the OSSD response time. Table 4-1 shows the possible configurable values. In the dual protection mode, it is possible to set a separate response time for each protection area.

When longer response time is configured, the stability of UAM can be increased. However, longer response time requires longer safety distance. User must perform risk assessment before configuring the response time. Addition of maximum 1 cycle (30ms) has to be taken into account for the area switching.

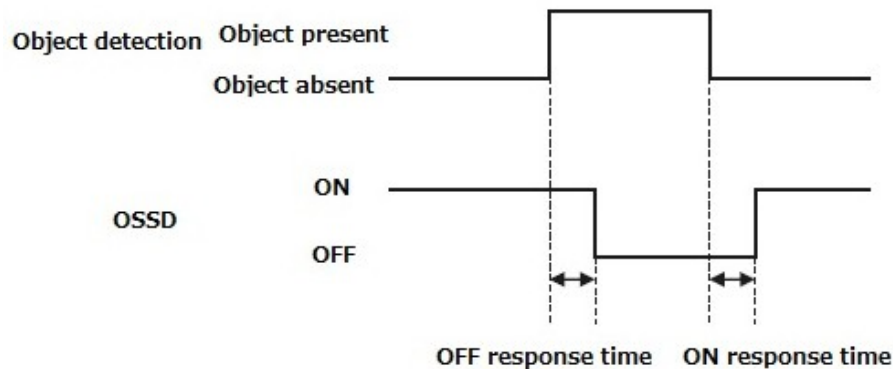

Table 4-1 Response time of UAM

	Response time (ms)							
	OFF	60	90	120	150	180	210	240
300		330	360	390	420	450	480	510
540		570	600	630	660	690	720	750
780		810	840	870	900	930	960	990
1020		1050	1080	1110	1140	1170	1200	1230
1260		1290	1320	1350	1380	1410	1440	1470
1500		1530	1560	1590	1620	1650	1680	1710
1740		1770	1800	1830	1860	1890	1920	1950
1980		2010						

	Response time (ms)							
	ON							
300		330	360	390	420	450	480	510
540		570	600	630	660	690	720	750
780		810	840	870	900	930	960	990
1020		1050	1080	1110	1140	1170	1200	1230
1260		1290	1320	1350	1380	1410	1440	1470
1500		1530	1560	1590	1620	1650	1680	1710
1740		1770	1800	1830	1860	1890	1920	1950
1980		2010						

* Default value

* Default value of OFF response time varies depending on the selected application when creating a “New” project. Refer to User's Manual for details.

* Minimum configurable response time in Master/Slave mode is,

- 120ms for OFF and 300ms for ON when the OSSDs of the slave units are not used.
- 60ms for OFF and 300ms for ON when the OSSDs of all the slave units are used.

Title	Safety Laser Scanner UAM-05LPA-T301C Specification	Drawing No.	C-62-00056	21 / 44
-------	---	----------------	------------	---------

4.9 Other outputs

UAM consist of 8 non-safety outputs, WARNING1, WARNING2, MUT_OUT1, MUT_OUT2, RES_REQ1, RES_REQ2, AUX_OUT1 and AUX_OUT2. WARNING1/OSSD3, WARNING2/OSSD4, RES_REQ1/MUT_OUT1/AUX_OUT1 and RES_REQ2/MUT_OUT2/AUX_OUT2 are configurable outputs that share the same terminal. When the functions are selected using UAM project designer, outputs are configured automatically.

4.9.1 Warning output 1 (WARNING 1)

This signal will switch to OFF-state when an obstacle is detected in the configured warning zone 1.

4.9.2 Warning output 2 (WARNING 2)

This signal will switch to OFF-state when an obstacle is detected in the configured warning zone 2.

4.9.3 Muting output 1 (MUT_OUT 1)

MUT_OUT1 indicates the muting/override status of the protection zone 1. When the muting function is activated, MUT_OUT1 will switch to ON-state. At the same time, number 37 is displayed on the 7-segment LED. This signal should be used to indicate that protection zone 1 is in muting state or override state.

4.9.4 Muting output 2 (MUT_OUT 2)

MUT_OUT2 indicates the muting/override status of the protection zone 2. When the muting function is activated, MUT_OUT2 will switch to ON-state. At the same time, number 38 is displayed on the 7-segment LED. This signal should be used to indicate that protection zone 2 is in muting state or override state.

When both protection zone 1 and protection zone 2 are in muting or override state, number 39 is displayed on the 7-segment LED.

4.9.5 Reset Request 1 (RES_REQ1)

This signal will switch to ON-state when the protection zone 1 of the UAM is ready to receive reset signal.

4.9.6 Reset Request 2 (RES_REQ2)

This signal will switch to ON-state when the protection zone 2 of the UAM is ready to receive reset signal.

4.9.7 Auxiliary Output 1 (AUX_OUT1)

See section 4.18 for the details.

4.9.8 Auxiliary Output 2 (AUX_OUT2)

See section 4.18 for the details.

Title	Safety Laser Scanner UAM-05LPA-T301C Specification	Drawing No.	C-62-00056	22 / 44
-------	---	----------------	------------	---------

4.10 Area switching

A maximum of 128 sets of area can be configured in UAM. However the maximum configurable area number differs depending on the selected function such as, muting and dual protection. Table 4-2 shows the maximum configurable area number according to the used mode.

External input signals are provided in UAM for switching the area. Each signal has a pair of normal and inverted signal. For example, it is necessary to provide both input signal IN_A and inverse IN_A signal to switch the area. Error will occur if IN_A and inverse IN_A signals do not complement each other. Table 4-3 below shows the combination of input signal to switch the area. Area in use will be displayed in the 7 segment LED of UAM.

It is also possible to configure area input delay. Configure the necessary delay required for the system to provide stable input signals to UAM. The default value is 30ms.

There are maximum 5 input pairs (a pair is combination of normal and inverted signal) in UAM therefore, it can operate with maximum 32 sets of area. Further, it is also possible to switch the area through the speed monitoring of incremental encoder signal connected to UAM. Maximum configurable area in encoder input mode is 128.

Table 4-2 Input combination for area switching

Mode	Protection	Max internal input	Max Area		Max encoder area
			Pair input mode	Fixed input mode	
Standard	1	5	32	128	—
	2	5	32	128	—
EDM	1	4	16	70	—
	2	4	16	70	—
MUTING / EDM	1	2	4	20	—
	2	1	2	2	—
Encoder *1	1	3	7	-	128*2
	2	3	7	-	128*2

*1: Muting function cannot be used if encoder input mode is selected.

*2: Among the 8 input patterns, at least one pattern must be used for encoder input. Other 7 remaining patterns can be selected to be used as static input or not in use. A pattern with encoder input mode can have maximum 128 sets of area.

Title	Safety Laser Scanner UAM-05LPA-T301C Specification	Drawing No.	C-62-00056	23 / 44
-------	---	----------------	------------	---------

■ Area Switching (Pair Input Mode)

In the pair input mode of area switching, input signals are always used in pairs, such as IN_A and IN \bar{A} . State of one signal will be always in the opposite state of the other in this mode. Table 4-3 (a ~ e) shows the state of input signals in the pair input mode for switching to the respective area.

Table 4-3 Input combination for area switching

a) In the case of 5 Input

	IN_A	IN_B	IN_C	IN_D	IN_E	IN \bar{A}	IN \bar{B}	IN \bar{C}	IN \bar{D}	IN \bar{E}
AREA_1	OFF	OFF	OFF	OFF	OFF	ON	ON	ON	ON	ON
AREA_2	OFF	OFF	OFF	OFF	ON	OFF	ON	ON	ON	ON
AREA_3	OFF	OFF	OFF	ON	OFF	OFF	ON	ON	ON	ON
AREA_4	OFF	OFF	ON	OFF	OFF	OFF	ON	ON	ON	ON
AREA_5	OFF	ON	OFF	OFF	OFF	OFF	ON	ON	ON	ON
AREA_6	ON	OFF	OFF	OFF	OFF	OFF	ON	ON	ON	ON
AREA_7	OFF	OFF	OFF	OFF	ON	ON	OFF	ON	ON	ON
AREA_8	OFF	OFF	OFF	ON	OFF	ON	OFF	ON	ON	ON
AREA_9	OFF	OFF	ON	OFF	OFF	ON	OFF	ON	ON	ON
AREA_10	OFF	ON	OFF	OFF	OFF	ON	OFF	ON	ON	ON
AREA_11	ON	OFF	OFF	OFF	OFF	ON	OFF	ON	ON	ON
AREA_12	OFF	OFF	OFF	ON	ON	OFF	OFF	ON	ON	ON
AREA_13	OFF	OFF	ON	OFF	ON	OFF	OFF	ON	ON	ON
AREA_14	OFF	ON	OFF	OFF	ON	OFF	OFF	ON	ON	ON
AREA_15	ON	OFF	OFF	OFF	ON	OFF	OFF	ON	ON	ON
AREA_16	OFF	OFF	ON	ON	OFF	OFF	OFF	ON	ON	ON
AREA_17	OFF	ON	OFF	ON	OFF	OFF	OFF	ON	ON	ON
AREA_18	ON	OFF	OFF	ON	OFF	OFF	OFF	ON	ON	ON
AREA_19	OFF	ON	ON	OFF	OFF	OFF	OFF	ON	ON	ON
AREA_20	ON	OFF	ON	OFF	OFF	OFF	OFF	ON	ON	ON
AREA_21	ON	ON	OFF	OFF	OFF	OFF	OFF	ON	ON	ON
AREA_22	OFF	OFF	OFF	OFF	ON	ON	ON	OFF	ON	ON
AREA_23	OFF	OFF	OFF	ON	OFF	ON	ON	OFF	ON	ON
AREA_24	OFF	OFF	ON	OFF	OFF	ON	ON	OFF	ON	ON
AREA_25	OFF	ON	OFF	OFF	OFF	ON	ON	OFF	ON	ON
AREA_26	ON	OFF	OFF	OFF	OFF	ON	ON	OFF	ON	ON
AREA_27	OFF	OFF	OFF	ON	ON	OFF	ON	OFF	ON	ON
AREA_28	OFF	OFF	ON	OFF	ON	OFF	ON	OFF	ON	ON
AREA_29	OFF	ON	OFF	OFF	ON	OFF	ON	OFF	ON	ON
AREA_30	ON	OFF	OFF	OFF	ON	OFF	ON	OFF	ON	ON
AREA_31	OFF	OFF	ON	ON	OFF	OFF	ON	OFF	ON	ON
AREA_32	OFF	ON	OFF	ON	OFF	OFF	ON	OFF	ON	ON

b) In the case of 4 Input number

	IN_A	IN_B	IN_C	IN_D	IN \bar{A}	IN \bar{B}	IN \bar{C}	IN \bar{D}
AREA_1	ON	ON	ON	ON	OFF	OFF	OFF	OFF
AREA_2	OFF	ON	ON	ON	ON	OFF	OFF	OFF
AREA_3	ON	OFF	ON	ON	OFF	ON	OFF	OFF
AREA_4	OFF	OFF	ON	ON	ON	ON	OFF	OFF
AREA_5	ON	ON	OFF	ON	OFF	OFF	ON	OFF
AREA_6	OFF	ON	OFF	ON	ON	OFF	ON	OFF
AREA_7	ON	OFF	OFF	ON	OFF	ON	ON	OFF
AREA_8	OFF	OFF	OFF	ON	ON	ON	ON	OFF
AREA_9	ON	ON	ON	OFF	OFF	OFF	OFF	ON
AREA_10	OFF	ON	ON	OFF	ON	OFF	OFF	ON
AREA_11	ON	OFF	ON	OFF	OFF	ON	OFF	ON
AREA_12	OFF	OFF	ON	OFF	ON	ON	OFF	ON
AREA_13	ON	ON	OFF	OFF	OFF	OFF	ON	ON
AREA_14	OFF	ON	OFF	OFF	ON	OFF	ON	ON
AREA_15	ON	OFF	OFF	OFF	OFF	ON	ON	ON
AREA_16	OFF	OFF	OFF	OFF	ON	ON	ON	ON

c) In the case of 3 Input number

	IN_A	IN_B	IN_C	IN \bar{A}	IN \bar{B}	IN \bar{C}
AREA_1	ON	ON	ON	OFF	OFF	OFF
AREA_2	OFF	ON	ON	ON	OFF	OFF
AREA_3	ON	OFF	ON	OFF	ON	OFF
AREA_4	OFF	OFF	ON	ON	ON	OFF
AREA_5	ON	ON	OFF	OFF	OFF	ON
AREA_6	OFF	ON	OFF	ON	OFF	ON
AREA_7	ON	OFF	OFF	OFF	ON	ON
AREA_8	OFF	OFF	OFF	ON	ON	ON

d) In the case of 2 Input number

	IN_A	IN_B	IN \bar{A}	IN \bar{B}
AREA_1	ON	ON	OFF	OFF
AREA_2	OFF	ON	ON	OFF
AREA_3	ON	OFF	OFF	ON
AREA_4	OFF	OFF	ON	ON

e) In the case of 1 input signal

	IN_A	IN \bar{A}
AREA_1	ON	OFF
AREA_2	OFF	ON

Title	Safety Laser Scanner UAM-05LPA-T301C Specification	Drawing No.	C-62-00056	25 / 44
-------	---	----------------	------------	---------

■ Area switching (Fixed Input Mode)

In this mode, a fixed number of input signals among the used inputs must be at ON state to determine the area number. The number of ON input signals should be half of the used input signals for switching the area correctly. For example, if the maximum user area is configured as 3, then 4-input signals (IN_A, IN_A̅, IN_B, IN_B̅) will be used for the area switching and any 2-input signals among them should be always at ON state to determine the area number.

Area numbers for the corresponding input states are shown in Table 4-4 (a ~ e). Please note that the same area will have different input states depending on the used number of input signals.

Table4-4 Input combination for area switching

a) When 10 input signals are used

	IN_A	IN_A̅	IN_B	IN_B̅	IN_C	IN_C̅	IN_D	IN_D̅	IN_E	IN_E̅
AREA_1	OFF	OFF	OFF	OFF	OFF	ON	ON	ON	ON	ON
AREA_2	OFF	OFF	OFF	OFF	ON	OFF	ON	ON	ON	ON
AREA_3	OFF	OFF	OFF	ON	OFF	OFF	ON	ON	ON	ON
AREA_4	OFF	OFF	ON	OFF	OFF	OFF	ON	ON	ON	ON
AREA_5	OFF	ON	OFF	OFF	OFF	OFF	ON	ON	ON	ON
AREA_6	ON	OFF	OFF	OFF	OFF	OFF	ON	ON	ON	ON
AREA_7	OFF	OFF	OFF	OFF	ON	ON	OFF	ON	ON	ON
AREA_8	OFF	OFF	OFF	ON	OFF	ON	OFF	ON	ON	ON
AREA_9	OFF	OFF	ON	OFF	OFF	ON	OFF	ON	ON	ON
AREA_10	OFF	ON	OFF	OFF	OFF	ON	OFF	ON	ON	ON
AREA_11	ON	OFF	OFF	OFF	OFF	ON	OFF	ON	ON	ON
AREA_12	OFF	OFF	OFF	ON	ON	OFF	OFF	ON	ON	ON
AREA_13	OFF	OFF	ON	OFF	ON	OFF	OFF	ON	ON	ON
AREA_14	OFF	ON	OFF	OFF	ON	OFF	OFF	ON	ON	ON
AREA_15	ON	OFF	OFF	OFF	ON	OFF	OFF	ON	ON	ON
AREA_16	OFF	OFF	ON	ON	OFF	OFF	OFF	ON	ON	ON
AREA_17	OFF	ON	OFF	ON	OFF	OFF	OFF	ON	ON	ON
AREA_18	ON	OFF	OFF	ON	OFF	OFF	OFF	ON	ON	ON
AREA_19	OFF	ON	ON	OFF	OFF	OFF	OFF	ON	ON	ON
AREA_20	ON	OFF	ON	OFF	OFF	OFF	OFF	ON	ON	ON
AREA_21	ON	ON	OFF	OFF	OFF	OFF	OFF	ON	ON	ON
AREA_22	OFF	OFF	OFF	OFF	ON	ON	ON	OFF	ON	ON
AREA_23	OFF	OFF	OFF	ON	OFF	ON	ON	OFF	ON	ON
AREA_24	OFF	OFF	ON	OFF	OFF	ON	ON	OFF	ON	ON
AREA_25	OFF	ON	OFF	OFF	OFF	ON	ON	OFF	ON	ON
AREA_26	ON	OFF	OFF	OFF	OFF	ON	ON	OFF	ON	ON
AREA_27	OFF	OFF	OFF	ON	ON	OFF	ON	OFF	ON	ON
AREA_28	OFF	OFF	ON	OFF	ON	OFF	ON	OFF	ON	ON
AREA_29	OFF	ON	OFF	OFF	ON	OFF	ON	OFF	ON	ON
AREA_30	ON	OFF	OFF	OFF	ON	OFF	ON	OFF	ON	ON
AREA_31	OFF	OFF	ON	ON	OFF	OFF	ON	OFF	ON	ON
AREA_32	OFF	ON	OFF	ON	OFF	OFF	ON	OFF	ON	ON

	IN_A	IN \bar{A}	IN_B	IN \bar{B}	IN_C	IN \bar{C}	IN_D	IN \bar{D}	IN_E	IN \bar{E}
AREA_33	ON	OFF	OFF	ON	OFF	OFF	ON	OFF	ON	ON
AREA_34	OFF	ON	ON	OFF	OFF	OFF	ON	OFF	ON	ON
AREA_35	ON	OFF	ON	OFF	OFF	OFF	ON	OFF	ON	ON
AREA_36	ON	ON	OFF	OFF	OFF	OFF	ON	OFF	ON	ON
AREA_37	OFF	OFF	OFF	ON	ON	ON	OFF	OFF	ON	ON
AREA_38	OFF	OFF	ON	OFF	ON	ON	OFF	OFF	ON	ON
AREA_39	OFF	ON	OFF	OFF	ON	ON	OFF	OFF	ON	ON
AREA_40	ON	OFF	OFF	OFF	ON	ON	OFF	OFF	ON	ON
AREA_41	OFF	OFF	ON	ON	OFF	ON	OFF	OFF	ON	ON
AREA_42	OFF	ON	OFF	ON	OFF	ON	OFF	OFF	ON	ON
AREA_43	ON	OFF	OFF	ON	OFF	ON	OFF	OFF	ON	ON
AREA_44	OFF	ON	ON	OFF	OFF	ON	OFF	OFF	ON	ON
AREA_45	ON	OFF	ON	OFF	OFF	ON	OFF	OFF	ON	ON
AREA_46	ON	ON	OFF	OFF	OFF	ON	OFF	OFF	ON	ON
AREA_47	OFF	OFF	ON	ON	ON	OFF	OFF	OFF	ON	ON
AREA_48	OFF	ON	OFF	ON	ON	OFF	OFF	OFF	ON	ON
AREA_49	ON	OFF	OFF	ON	ON	OFF	OFF	OFF	ON	ON
AREA_50	OFF	ON	ON	OFF	ON	OFF	OFF	OFF	ON	ON
AREA_51	ON	OFF	ON	OFF	ON	OFF	OFF	OFF	ON	ON
AREA_52	ON	ON	OFF	OFF	ON	OFF	OFF	OFF	ON	ON
AREA_53	OFF	ON	ON	ON	OFF	OFF	OFF	OFF	ON	ON
AREA_54	ON	OFF	ON	ON	OFF	OFF	OFF	OFF	ON	ON
AREA_55	ON	ON	OFF	ON	OFF	OFF	OFF	OFF	ON	ON
AREA_56	ON	ON	ON	OFF	OFF	OFF	OFF	OFF	ON	ON
AREA_57	OFF	OFF	OFF	OFF	ON	ON	ON	ON	OFF	ON
AREA_58	OFF	OFF	OFF	ON	OFF	ON	ON	ON	OFF	ON
AREA_59	OFF	OFF	ON	OFF	OFF	ON	ON	ON	OFF	ON
AREA_60	OFF	ON	OFF	OFF	OFF	ON	ON	ON	OFF	ON
AREA_61	ON	OFF	OFF	OFF	OFF	ON	ON	ON	OFF	ON
AREA_62	OFF	OFF	OFF	ON	ON	OFF	ON	ON	OFF	ON
AREA_63	OFF	OFF	ON	OFF	ON	OFF	ON	ON	OFF	ON
AREA_64	OFF	ON	OFF	OFF	ON	OFF	ON	ON	OFF	ON
AREA_65	ON	OFF	OFF	OFF	ON	OFF	ON	ON	OFF	ON
AREA_66	OFF	OFF	ON	ON	OFF	OFF	ON	ON	OFF	ON
AREA_67	OFF	ON	OFF	ON	OFF	OFF	ON	ON	OFF	ON
AREA_68	ON	OFF	OFF	ON	OFF	OFF	ON	ON	OFF	ON
AREA_69	OFF	ON	ON	OFF	OFF	OFF	ON	ON	OFF	ON
AREA_70	ON	OFF	ON	OFF	OFF	OFF	ON	ON	OFF	ON
AREA_71	ON	ON	OFF	OFF	OFF	OFF	ON	ON	OFF	ON
AREA_72	OFF	OFF	OFF	ON	ON	ON	OFF	ON	OFF	ON
AREA_73	OFF	OFF	ON	OFF	ON	ON	OFF	ON	OFF	ON
AREA_74	OFF	ON	OFF	OFF	ON	ON	OFF	ON	OFF	ON
AREA_75	ON	OFF	OFF	OFF	ON	ON	OFF	ON	OFF	ON
AREA_76	OFF	OFF	ON	ON	OFF	ON	OFF	ON	OFF	ON

Title	Safety Laser Scanner UAM-05LPA-T301C Specification	Drawing No.	C-62-00056	27 / 44
-------	---	----------------	------------	---------

	IN_A	IN \bar{A}	IN_B	IN \bar{B}	IN_C	IN \bar{C}	IN_D	IN \bar{D}	IN_E	IN \bar{E}
AREA_77	OFF	ON	OFF	ON	OFF	ON	OFF	ON	OFF	ON
AREA_78	ON	OFF	OFF	ON	OFF	ON	OFF	ON	OFF	ON
AREA_79	OFF	ON	ON	OFF	OFF	ON	OFF	ON	OFF	ON
AREA_80	ON	OFF	ON	OFF	OFF	ON	OFF	ON	OFF	ON
AREA_81	ON	ON	OFF	OFF	OFF	ON	OFF	ON	OFF	ON
AREA_82	OFF	OFF	ON	ON	ON	OFF	OFF	ON	OFF	ON
AREA_83	OFF	ON	OFF	ON	ON	OFF	OFF	ON	OFF	ON
AREA_84	ON	OFF	OFF	ON	ON	OFF	OFF	ON	OFF	ON
AREA_85	OFF	ON	ON	OFF	ON	OFF	OFF	ON	OFF	ON
AREA_86	ON	OFF	ON	OFF	ON	OFF	OFF	ON	OFF	ON
AREA_87	ON	ON	OFF	OFF	ON	OFF	OFF	ON	OFF	ON
AREA_88	OFF	ON	ON	ON	OFF	OFF	OFF	ON	OFF	ON
AREA_89	ON	OFF	ON	ON	OFF	OFF	OFF	ON	OFF	ON
AREA_90	ON	ON	OFF	ON	OFF	OFF	OFF	ON	OFF	ON
AREA_91	ON	ON	ON	OFF	OFF	OFF	OFF	ON	OFF	ON
AREA_92	OFF	OFF	OFF	ON	ON	ON	ON	OFF	OFF	ON
AREA_93	OFF	OFF	ON	OFF	ON	ON	ON	OFF	OFF	ON
AREA_94	OFF	ON	OFF	OFF	ON	ON	ON	OFF	OFF	ON
AREA_95	ON	OFF	OFF	OFF	ON	ON	ON	OFF	OFF	ON
AREA_96	OFF	OFF	ON	ON	OFF	ON	ON	OFF	OFF	ON
AREA_97	OFF	ON	OFF	ON	OFF	ON	ON	OFF	OFF	ON
AREA_98	ON	OFF	OFF	ON	OFF	ON	ON	OFF	OFF	ON
AREA_99	OFF	ON	ON	OFF	OFF	ON	ON	OFF	OFF	ON
AREA_100	ON	OFF	ON	OFF	OFF	ON	ON	OFF	OFF	ON
AREA_101	ON	ON	OFF	OFF	OFF	ON	ON	OFF	OFF	ON
AREA_102	OFF	OFF	ON	ON	ON	OFF	ON	OFF	OFF	ON
AREA_103	OFF	ON	OFF	ON	ON	OFF	ON	OFF	OFF	ON
AREA_104	ON	OFF	OFF	ON	ON	OFF	ON	OFF	OFF	ON
AREA_105	OFF	ON	ON	OFF	ON	OFF	ON	OFF	OFF	ON
AREA_106	ON	OFF	ON	OFF	ON	OFF	ON	OFF	OFF	ON
AREA_107	ON	ON	OFF	OFF	ON	OFF	ON	OFF	OFF	ON
AREA_108	OFF	ON	ON	ON	OFF	OFF	ON	OFF	OFF	ON
AREA_109	ON	OFF	ON	ON	OFF	OFF	ON	OFF	OFF	ON
AREA_110	ON	ON	OFF	ON	OFF	OFF	ON	OFF	OFF	ON
AREA_111	ON	ON	ON	OFF	OFF	OFF	ON	OFF	OFF	ON
AREA_112	OFF	OFF	ON	ON	ON	ON	OFF	OFF	OFF	ON
AREA_113	OFF	ON	OFF	ON	ON	ON	OFF	OFF	OFF	ON
AREA_114	ON	OFF	OFF	ON	ON	ON	OFF	OFF	OFF	ON
AREA_115	OFF	ON	ON	OFF	ON	ON	OFF	OFF	OFF	ON
AREA_116	ON	OFF	ON	OFF	ON	ON	OFF	OFF	OFF	ON
AREA_117	ON	ON	OFF	OFF	ON	ON	OFF	OFF	OFF	ON
AREA_118	OFF	ON	ON	ON	OFF	ON	OFF	OFF	OFF	ON
AREA_119	ON	OFF	ON	ON	OFF	ON	OFF	OFF	OFF	ON
AREA_120	ON	ON	OFF	ON	OFF	ON	OFF	OFF	OFF	ON
AREA_121	ON	ON	ON	OFF	OFF	ON	OFF	OFF	OFF	ON

Title	Safety Laser Scanner UAM-05LPA-T301C Specification	Drawing No.	C-62-00056	28 / 44
-------	---	----------------	------------	---------

	IN_A	IN \bar{A}	IN_B	IN \bar{B}	IN_C	IN \bar{C}	IN_D	IN \bar{D}	IN_E	IN \bar{E}
AREA_122	OFF	ON	ON	ON	ON	OFF	OFF	OFF	OFF	ON
AREA_123	ON	OFF	ON	ON	ON	OFF	OFF	OFF	OFF	ON
AREA_124	ON	ON	OFF	ON	ON	OFF	OFF	OFF	OFF	ON
AREA_125	ON	ON	ON	OFF	ON	OFF	OFF	OFF	OFF	ON
AREA_126	ON	ON	ON	ON	OFF	OFF	OFF	OFF	OFF	ON
AREA_127	OFF	OFF	OFF	OFF	ON	ON	ON	ON	ON	OFF
AREA_128	OFF	OFF	OFF	ON	OFF	ON	ON	ON	ON	OFF

b) When 8 input signals are used

	IN_A	IN \bar{A}	IN_B	IN \bar{B}	IN_C	IN \bar{C}	IN_D	IN \bar{D}
AREA_1	OFF	OFF	OFF	OFF	ON	ON	ON	ON
AREA_2	OFF	OFF	OFF	ON	OFF	ON	ON	ON
AREA_3	OFF	OFF	ON	OFF	OFF	ON	ON	ON
AREA_4	OFF	ON	OFF	OFF	OFF	ON	ON	ON
AREA_5	ON	OFF	OFF	OFF	OFF	ON	ON	ON
AREA_6	OFF	OFF	OFF	ON	ON	OFF	ON	ON
AREA_7	OFF	OFF	ON	OFF	ON	OFF	ON	ON
AREA_8	OFF	ON	OFF	OFF	ON	OFF	ON	ON
AREA_9	ON	OFF	OFF	OFF	ON	OFF	ON	ON
AREA_10	OFF	OFF	ON	ON	OFF	OFF	ON	ON
AREA_11	OFF	ON	OFF	ON	OFF	OFF	ON	ON
AREA_12	ON	OFF	OFF	ON	OFF	OFF	ON	ON
AREA_13	OFF	ON	ON	OFF	OFF	OFF	ON	ON
AREA_14	ON	OFF	ON	OFF	OFF	OFF	ON	ON
AREA_15	ON	ON	OFF	OFF	OFF	OFF	ON	ON
AREA_16	OFF	OFF	OFF	ON	ON	ON	OFF	ON
AREA_17	OFF	OFF	ON	OFF	ON	ON	OFF	ON
AREA_18	OFF	ON	OFF	OFF	ON	ON	OFF	ON
AREA_19	ON	OFF	OFF	OFF	ON	ON	OFF	ON
AREA_20	OFF	OFF	ON	ON	OFF	ON	OFF	ON
AREA_21	OFF	ON	OFF	ON	OFF	ON	OFF	ON
AREA_22	ON	OFF	OFF	ON	OFF	ON	OFF	ON
AREA_23	OFF	ON	ON	OFF	OFF	ON	OFF	ON
AREA_24	ON	OFF	ON	OFF	OFF	ON	OFF	ON
AREA_25	ON	ON	OFF	OFF	OFF	ON	OFF	ON
AREA_26	OFF	OFF	ON	ON	ON	OFF	OFF	ON
AREA_27	OFF	ON	OFF	ON	ON	OFF	OFF	ON
AREA_28	ON	OFF	OFF	ON	ON	OFF	OFF	ON
AREA_29	OFF	ON	ON	OFF	ON	OFF	OFF	ON
AREA_30	ON	OFF	ON	OFF	ON	OFF	OFF	ON
AREA_31	ON	ON	OFF	OFF	ON	OFF	OFF	ON
AREA_32	OFF	ON	ON	ON	OFF	OFF	OFF	ON

Title	Safety Laser Scanner UAM-05LPA-T301C Specification	Drawing No.	C-62-00056	29 / 44
-------	---	----------------	------------	---------

	IN_A	IN \bar A	IN_B	IN \bar B	IN_C	IN \bar C	IN_D	IN \bar D
AREA_33	ON	OFF	ON	ON	OFF	OFF	OFF	ON
AREA_34	ON	ON	OFF	ON	OFF	OFF	OFF	ON
AREA_35	ON	ON	ON	OFF	OFF	OFF	OFF	ON
AREA_36	OFF	OFF	OFF	ON	ON	ON	ON	OFF
AREA_37	OFF	OFF	ON	OFF	ON	ON	ON	OFF
AREA_38	OFF	ON	OFF	OFF	ON	ON	ON	OFF
AREA_39	ON	OFF	OFF	OFF	ON	ON	ON	OFF
AREA_40	OFF	OFF	ON	ON	OFF	ON	ON	OFF
AREA_41	OFF	ON	OFF	ON	OFF	ON	ON	OFF
AREA_42	ON	OFF	OFF	ON	OFF	ON	ON	OFF
AREA_43	OFF	ON	ON	OFF	OFF	ON	ON	OFF
AREA_44	ON	OFF	ON	OFF	OFF	ON	ON	OFF
AREA_45	ON	ON	OFF	OFF	OFF	ON	ON	OFF
AREA_46	OFF	OFF	ON	ON	ON	OFF	ON	OFF
AREA_47	OFF	ON	OFF	ON	ON	OFF	ON	OFF
AREA_48	ON	OFF	OFF	ON	ON	OFF	ON	OFF
AREA_49	OFF	ON	ON	OFF	ON	OFF	ON	OFF
AREA_50	ON	OFF	ON	OFF	ON	OFF	ON	OFF
AREA_51	ON	ON	OFF	OFF	ON	OFF	ON	OFF
AREA_52	OFF	ON	ON	ON	OFF	OFF	ON	OFF
AREA_53	ON	OFF	ON	ON	OFF	OFF	ON	OFF
AREA_54	ON	ON	OFF	ON	OFF	OFF	ON	OFF
AREA_55	ON	ON	ON	OFF	OFF	OFF	ON	OFF
AREA_56	OFF	OFF	ON	ON	ON	ON	OFF	OFF
AREA_57	OFF	ON	OFF	ON	ON	ON	OFF	OFF
AREA_58	ON	OFF	OFF	ON	ON	ON	OFF	OFF
AREA_59	OFF	ON	ON	OFF	ON	ON	OFF	OFF
AREA_60	ON	OFF	ON	OFF	ON	ON	OFF	OFF
AREA_61	ON	ON	OFF	OFF	ON	ON	OFF	OFF
AREA_62	OFF	ON	ON	ON	OFF	ON	OFF	OFF
AREA_63	ON	OFF	ON	ON	OFF	ON	OFF	OFF
AREA_64	ON	ON	OFF	ON	OFF	ON	OFF	OFF
AREA_65	ON	ON	ON	OFF	OFF	ON	OFF	OFF
AREA_66	OFF	ON	ON	ON	ON	OFF	OFF	OFF
AREA_67	ON	OFF	ON	ON	ON	OFF	OFF	OFF
AREA_68	ON	ON	OFF	ON	ON	OFF	OFF	OFF
AREA_69	ON	ON	ON	OFF	ON	OFF	OFF	OFF
AREA_70	ON	ON	ON	ON	OFF	OFF	OFF	OFF

Title	Safety Laser Scanner UAM-05LPA-T301C Specification	Drawing No.	C-62-00056	30 / 44
-------	---	----------------	------------	---------

c) When 6 input signals are used

	IN_A	IN \bar{A}	IN_B	IN \bar{B}	IN_C*1	IN \bar{C} *1
AREA_1	OFF	OFF	OFF	ON	ON	ON
AREA_2	OFF	OFF	ON	OFF	ON	ON
AREA_3	OFF	ON	OFF	OFF	ON	ON
AREA_4	ON	OFF	OFF	OFF	ON	ON
AREA_5	OFF	OFF	ON	ON	OFF	ON
AREA_6	OFF	ON	OFF	ON	OFF	ON
AREA_7	ON	OFF	OFF	ON	OFF	ON
AREA_8	OFF	ON	ON	OFF	OFF	ON
AREA_9	ON	OFF	ON	OFF	OFF	ON
AREA_10	ON	ON	OFF	OFF	OFF	ON
AREA_11	OFF	OFF	ON	ON	ON	OFF
AREA_12	OFF	ON	OFF	ON	ON	OFF
AREA_13	ON	OFF	OFF	ON	ON	OFF
AREA_14	OFF	ON	ON	OFF	ON	OFF
AREA_15	ON	OFF	ON	OFF	ON	OFF
AREA_16	ON	ON	OFF	OFF	ON	OFF
AREA_17	OFF	ON	ON	ON	OFF	OFF
AREA_18	ON	OFF	ON	ON	OFF	OFF
AREA_19	ON	ON	OFF	ON	OFF	OFF
AREA_20	ON	ON	ON	OFF	OFF	OFF

*1: Use signals IN \bar{E} and IN \bar{E} in place of IN_C and IN \bar{C} when using the muting function.

d) When 4 input signals are used

	IN_A	IN \bar{A}	IN_B*1	IN \bar{B} *1
AREA_1	OFF	OFF	ON	ON
AREA_2	OFF	ON	OFF	ON
AREA_3	ON	OFF	OFF	ON
AREA_4	OFF	ON	ON	OFF
AREA_5	ON	OFF	ON	OFF
AREA_6	ON	ON	OFF	OFF

*1: Use signals IN \bar{E} and IN \bar{E} in place of IN_B and IN \bar{B} when using the muting function.

e) When 2 input signals are used

	IN_A	IN \bar{A}
AREA_1	OFF	ON
AREA_2	ON	OFF

Title	Safety Laser Scanner UAM-05LPA-T301C Specification	Drawing No.	C-62-00056	31 / 44
-------	---	----------------	------------	---------

4.11 Incremental encoder

In UAM there are 2 pairs of encoder input terminals for connecting 2 units of dual channel incremental encoder signals. Area will be switched depending on the encoder speed. Direction of travel is detected by encoder's phase A and phase B signals having the phase difference of 90°. Speed and rotating direction of both encoders are constantly monitored to detect abnormal travel and stop the AGV.

Incremental encoder output signals should be connected to the respective input terminals of UAM. There are two patterns of signals generated by the combination of Phase A and Phase B of encoders depending on the direction of travel (Figure 4-17). In the first pattern, Phase B is 90 degrees ahead of Phase A wherein, at the rising edge of Phase A, state of Phase B is "H". This pattern is considered as positive direction (forward motion). In the second pattern, Phase B lags behind Phase A by 90 degrees and the state of Phase B at the rising edge of Phase A is "L". This is considered as negative direction (backward motion).

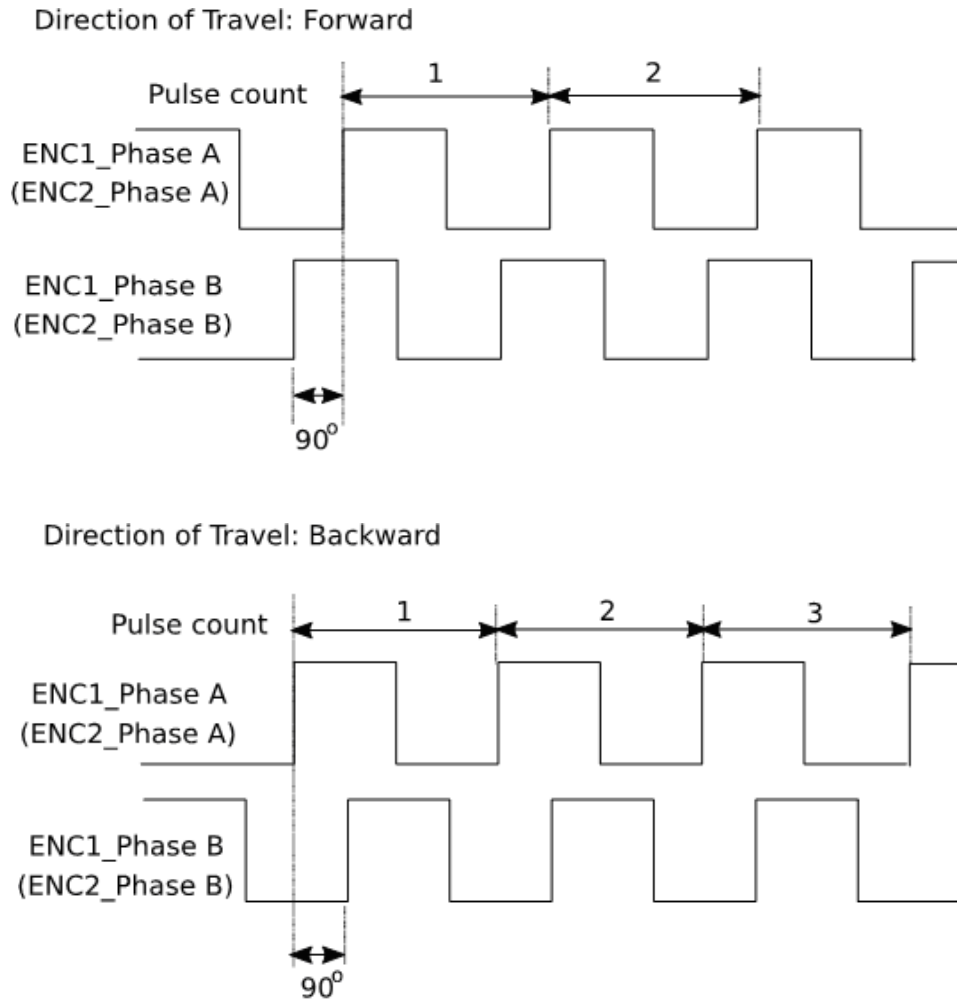

Figure 4-17 Input signal through Incremental encoder

Title	Safety Laser Scanner UAM-05LPA-T301C Specification	Drawing No.	C-62-00056	32 / 44
-------	---	----------------	------------	---------

4.11.1 Pulse per cm travel generated by incremental encoders

When AGV travels, incremental encoder generates pulses due to the transmission ratio between AVG tires and incremental encoder frictional wheel. Pulse count per cm depends on AGV's speed.

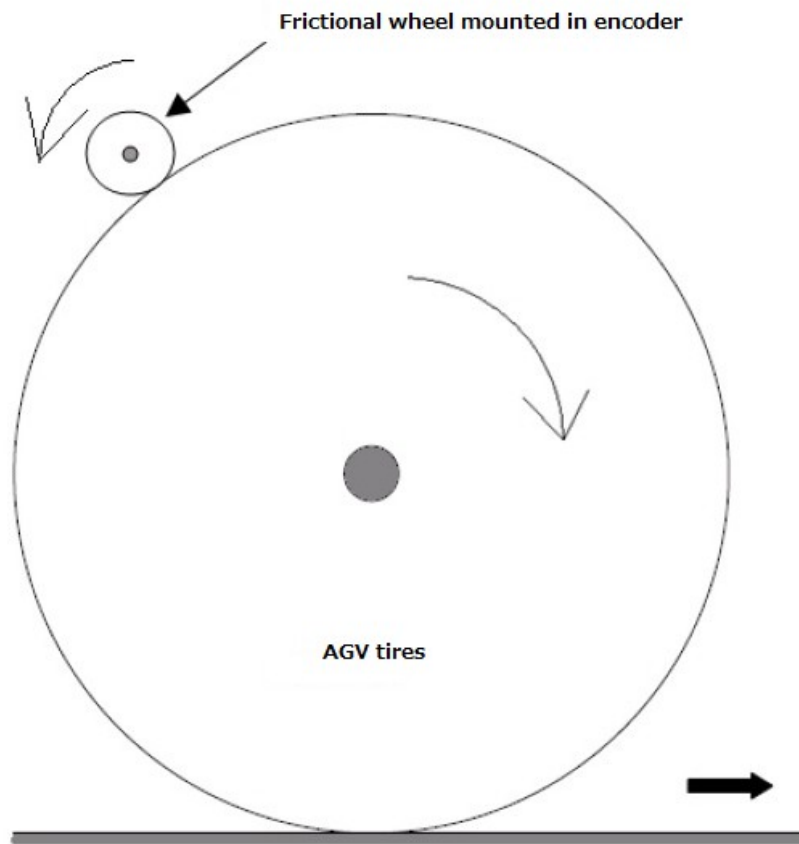

Figure 4-18 Calculation of pulse count for per centimeter travel

- AGV tire diameter : 40 cm
- Frictional wheel diameter mounted in incremental encoder: 5 cm
- Incremental encoder pulse number per revolution : 1000 pulse

AGV tire circumference = Diameter \times Circumference ratio = 40 cm \times 3.14 = 125.6 cm

AGV tire's one rotation is equivalent to 8 rotation of frictional wheel. This equals to the 8,000 pulse of incremental encoder.

From above, incremental encoder pulse count per cm is obtained as

$$8,000/125.6 = 63.7$$

While setting encoder parameters (Encoder Pulse1 and Encoder Pulse2) in UAM project Designer, set the encoder pulse count after rounding the calculated value to nearest whole number (64 in this case)

In the explanation above, the transfer method of the rotation was based on the frictional wheel. Same method can be applied for other cases to estimate the pulse count generated for one rotation of the wheel.

Title	Safety Laser Scanner UAM-05LPA-T301C Specification	Drawing No.	C-62-00056	33 / 44
-------	---	----------------	------------	---------

4.11.2 Area switching by encoder input

When the encoder input function is enabled using the UAM Project Designer, parameters related to encoder function are visible. First, select the number of encoders. If 2 encoders (1 and 2) are selected, operating area of the UAM can be switched based on the velocity of the AGV. If 4 encoders (1,2, 3, 4) are selected, operating area of the UAM can be switched based on the velocity and angular velocity (estimated by velocity difference between encoders on left and right side) of the AGV.

To estimate the velocity and angular velocity using 4 encoders, specify the location of encoders on the right and left side of the AGV along with the base line (distance between the right and left AGV wheels).

Next, specify the encoder velocity error tolerance and encoder pulse count per cm. Maximum velocity and maximum angular velocity are calculated automatically by considering the maximum encoder pulse frequency as 100KHz.

Encoder 3 and 4 can be connected to either IN_B, IN_E or RESET terminals of the UAM. If RESET terminal is selected, the interlock function cannot be used however, there will be up to 4 input patterns available for the encoder input function.

When encoder function is enabled, number of patterns can be selected from available external inputs. For each pattern, select either to use it as static input or the encoder input or not in use. It is necessary to select at least one pattern for encoder input.

For the patterns assigned to encoder input, a maximum 128 sets of area switching can be performed for the range of velocities. Further, it is possible to divide angular velocity to 15.

Figure 4-19(a) shows an example of encoder input setting for 2 encoders (Encoder 1, 2). Active area counts (max. 128) is selected on the sensing setting of the UAM Project Designer. In this example, pattern 1 is used as encoder input. Velocity is divided into 5 ranges. For each velocity range an area number is assigned as shown below.

From velocity [cm/sec]	To velocity [cm/sec]	Select area
-2000	10	Area 1
11	11	Area 1
12	12	Area 1
13	13	Area 1

Figure 4-19(a) Example of pattern switching through encoder input

Figure 4-19(b) shows the example of encoder input setting for 4 encoders (Encoder 1, 2, 3, 4). Velocity and angular velocity are divided into 7 and 5 ranges respectively and an area is assigned to each range. Cells can be filled with [--] for the unused velocity range. UAM will report error if such velocities are detected during the operation and OSSD signal will be switched off.

Velocity Range	Angular Velocity [deg/sec]				
	-36	-5	0	5	22
~	~	~	~	~	~
~	-6	-1	4	21	22
1000 ~ 500	Area 15	--	Area 1	--	Area 11
499 ~ 100	Area 14	--	Area 2	--	Area 10
99 ~ 11	Area 13	Area 12	Area 3	Area 8	Area 9
10 ~ -11	--	--	Area 4	--	--
-12 ~ -50	Area 17	Area 16	Area 5	Area 16	Area 17
-51 ~ -100	--	--	Area 6	--	--
-101 ~ -101	--	--	Area 7	--	--

Figure 4-19 (b) Example of encoder input setting

A calculation tool is provided in the UAM Project Designer to calculate the angular velocity when 4 encoders are used (Figure 4-19(c)). When velocities of right and left side encoders are entered the corresponding angular velocity is automatically calculated and displayed on the tool.

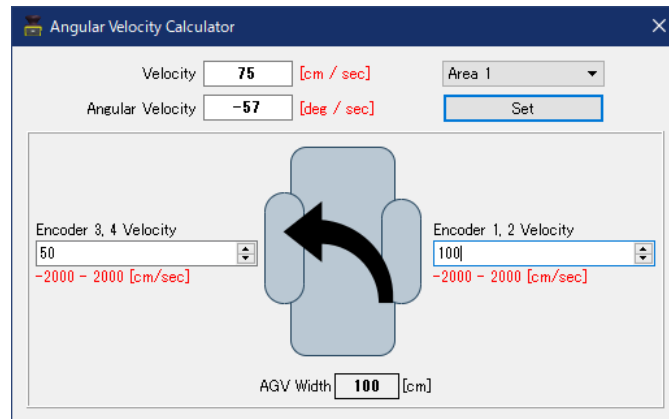

Figure 4-19 (c) Angular velocity calculation tool

The upward direction (positive velocity) in the UAM Project Designer corresponds to the forward direction whereas downward direction (negative velocity) corresponds to the backward direction. Further, positive angular velocity corresponds to clockwise turn and negative angular velocity corresponds to the counter clockwise turn. In Figure 3-12(c), The encoder velocity of the right-side encoders (Encoder 1, 2) is greater than the left-side encoders (Encoder 3, 4) therefore, the it is considered right turn (negative angular velocity).

Following formula is used for calculating the velocity and angular velocity in the UAM.

$$\begin{aligned} \text{Velocity:} \quad & V = \frac{V_R + V_L}{2} \quad \text{cm/s} \\ \text{Angular velocity:} \quad & W = \frac{180(V_L - V_R)}{\pi D} \quad \text{deg/s} \end{aligned}$$

where,

VR: Velocity of the encoder on the right side

VL: Velocity of the encoder on the left side

When a pattern is set for the static input, area number for that input and encoder velocity and angular velocity monitoring for the corresponding input pattern can be configured. Velocity (angular velocity) monitoring function monitors the encoder velocity during the operation and if it exceeds the specified limit OSSD will be switched to OFF state. Further, it is also possible to individually monitor the speed of encoders by selecting the independent check checkbox.

Figure 4-19 shows an example of configuring the static input function. Input pattern2 is configured to operate in static input mode with Area1 assigned to it. Velocity monitoring function is enabled with monitoring range 20 to 500cm/s.

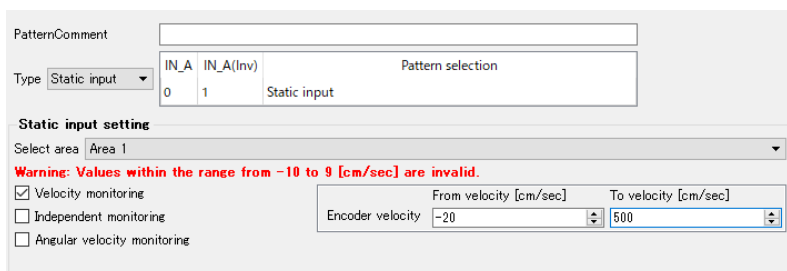

Figure 4-19(d) Example of static input mode configuration

Title	Safety Laser Scanner UAM-05LPA-T301C Specification	Drawing No.	C-62-00056	35 / 44
-------	---	----------------	------------	---------

4.12 Ethernet Setting

● Default setting

Factory default value is shown below.

IP address : 192.168.0.10
 Default gateway : 192.168.0.1
 Subnet mask : 255.255.255.0
 Port number : 10940

● Changing the IP address

IP address can be changed by using UAM project Designer. Refer to User's Manual for details.

4.13 Function to configure UAM by SD card

Configuration generated by UAM Project Designer can be saved in the SD card. It is possible to transfer the setting directly from the SD Card to UAM without connecting to a PC. Recommended specification of SD card is given below.

Create a project file with set the serial number and password of the UAM and save it on the SD card using UAM Project Designer. When the SD card is inserted to the specified UAM, settings are automatically transferred. It is possible to register multiple serial number and password in the SD card to simultaneously configure multiple devices. Setting will not be transferred to the unspecified UAM or if the password verification fails.

4.14 Master-Slave Function

Maximum 4 units of UAM can be interconnected using RS-485 for Master/slave operation. One unit will function as a master unit communicating with up to 3 units that function as slaves via safety communication channel. Use the UAM Project Designer to configure the devices. UAM will report error if the number of master and slave units is different than the configured settings.

Area switching of the slave unit is linked with the master unit while the slave units transmit the object detection information to the master which controls the OSSD. It is also possible to use each slave unit's OSSD. Figure 4-20 shows the connection example.

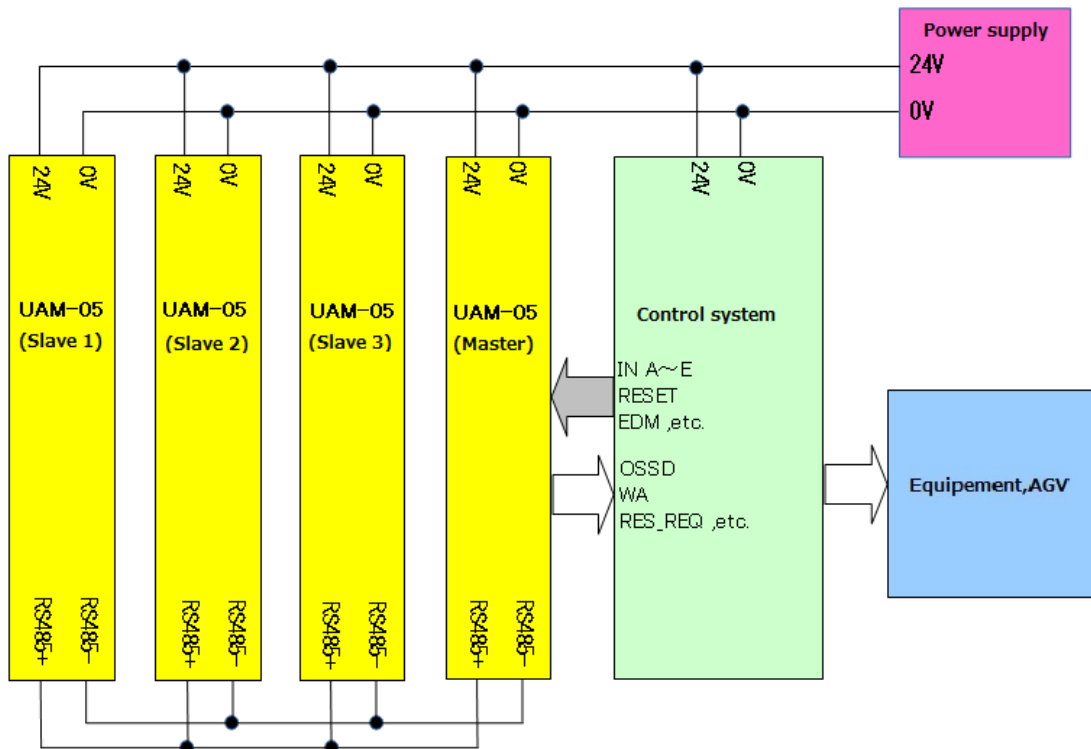

Figure 4-20 Connection example (When OSSD of slaves are not in use)

Title	Safety Laser Scanner UAM-05LPA-T301C Specification	Drawing No.	C-62-00056	36 / 44
-------	---	----------------	------------	---------

4.15 Laser Off Mode

Laser off mode is a function to completely stop the laser emission in the measurement region in order to prevent the interference to the surrounding equipment.

When this mode is enabled, Area1 is automatically assigned for laser off function. During the operation, UAM will stop the laser emission and switch the OSSD to OFF state whenever the area is switched to Area1.

4.16 Scan Skip Function

Scan skip is a function to stop the laser emission for a specified number of scan cycles in the measurement region in order to reduce the interference to the surrounding equipment.

When this function is enabled by specifying the skip count, UAM will operate by skipping the scan for the number of cycles. During the skipping cycle the laser is switched off in the measurement region. Configurable value for skip cycle is 0 ~ 3 count. Response time of UAM for the different settings is shown in Table 4-5.

Figure 4-21 shows the operating concept when the scan skip is 0. In this configuration the scan skip function is disabled and sensor operates normally.

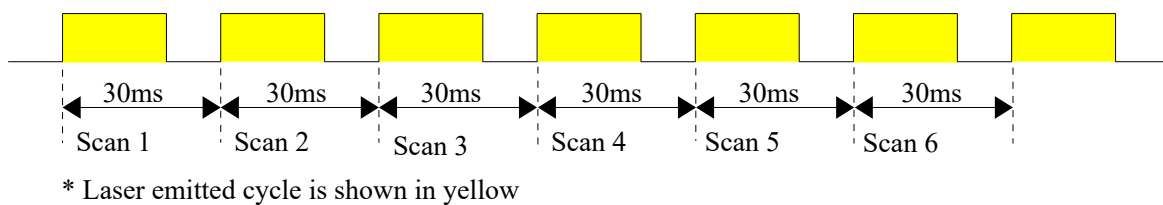

Figure 4-21 Operation of UAM when scan skip count is 0

Figure 4-22 shows the operating concept when the scan skip is set to 2. In this configuration UAM will skip the measurement for every 2 cycles in between the normal measurement cycles. Outputs states just before the skipping cycle are retained during the skipping cycle.

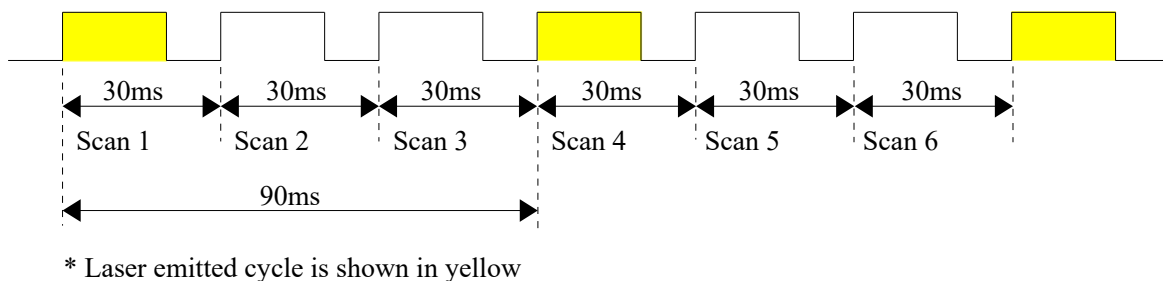

Figure 4-22 Operation of UAM when scan skip count is 2

Title	Safety Laser Scanner UAM-05LPA-T301C Specification	Drawing No.	C-62-00056	37 / 44
-------	---	----------------	------------	---------

Table 4-5 Response time for different scan skip settings

Master-Slave function disabled or when the slave OSSDs are used in master-slave mode.

Scan skip count	Off Response time (ms)							
1	90	150	210	270	330	390	450	510
	570	630	690	750	810	870	930	990
	1050	1110	1170	1230	1290	1350	1410	1470
	1530	1590	1650	1710	1770	1830	1890	1950
	2010							
2	120	210	300	390	480	570	660	750
	840	930	1020	1110	1200	1290	1380	1470
	1560	1650	1740	1830	1920	2010		
3	150	270	390	510	630	750	870	990
	1110	1230	1350	1470	1590	1710	1830	1950

Scan skip count	On Response time (ms)							
1	270	330	390	450	510	570	630	690
	750	810	870	930	990	1050	1110	1170
	1230	1290	1350	1410	1470	1530	1590	1650
	1710	1770	1830	1890	1950	2010		
2	300	390	480	570	660	750	840	930
	1020	1110	1200	1290	1380	1470	1560	1650
	1740	1830	1920	2010				
3	270	390	510	630	750	870	990	1110
	1230	1350	1470	1590	1710	1830	1950	

Master-Slave function enabled and slave OSSD outputs are not used

Scan skip count	Off Response time (ms)							
1	150	210	270	330	390	450	510	570
	630	690	750	810	870	930	990	1050
	1110	1170	1230	1290	1350	1410	1470	1530
	1590	1650	1710	1770	1830	1890	1950	2010
2	180	270	360	450	540	630	720	810
	900	990	1080	1170	1260	1350	1440	1530
	1620	1710	1800	1890	1980			
3	210	330	450	570	690	810	930	1050
	1170	1290	1410	1530	1650	1770	1890	2010

Scan skip count	On Response time (ms)							
1	330	390	450	510	570	630	690	750
	810	870	930	990	1050	1110	1170	1230
	1290	1350	1410	1470	1530	1590	1650	1710
	1770	1830	1890	1950	2010			
2	360	450	540	630	720	810	900	990
	1080	1170	1260	1350	1440	1530	1620	1710
	1800	1890	1980					
3	330	450	570	690	810	930	1050	1170
	1290	1410	1530	1650	1770	1890	2010	

Title	Safety Laser Scanner UAM-05LPA-T301C Specification	Drawing No.	C-62-00056	38 / 44
-------	---	----------------	------------	---------

4.17 Optical Window Contamination Warning Function

This is a function to warn the optical window contamination by blinking the 7-segment display number before contamination level reaches the maximum limit causing the OSSD signals to switch to OFF state. Cleaning the optical window at the blinking stage will prevent the unnecessary stop due to contamination error. No specific configuration is necessary to activate this function.

4.18 Auxiliary Output Function

Auxiliary output signals, AUX_OUT1 and AUX_OUT2 can be assigned to one of the following functions shown on the table below. However, it will be automatically assigned to Reset Request signal if the interlock function is enabled or Muting output signal if the muting function is enabled.

Output	Details
Synchronous signal	UAM generates 1ms pulse in every scan.
Error	Signal goes to ON state when UAM is in error state.
Window contamination error	Signal goes to ON state when contamination on the optical window reaches the error level.
Window contamination warning	Signal goes to ON state when contamination on the optical window reaches the warning level.

<Synchronous signal timing chart>

UAM outputs a signal synchronized with its scan at the time shown in the figure below.

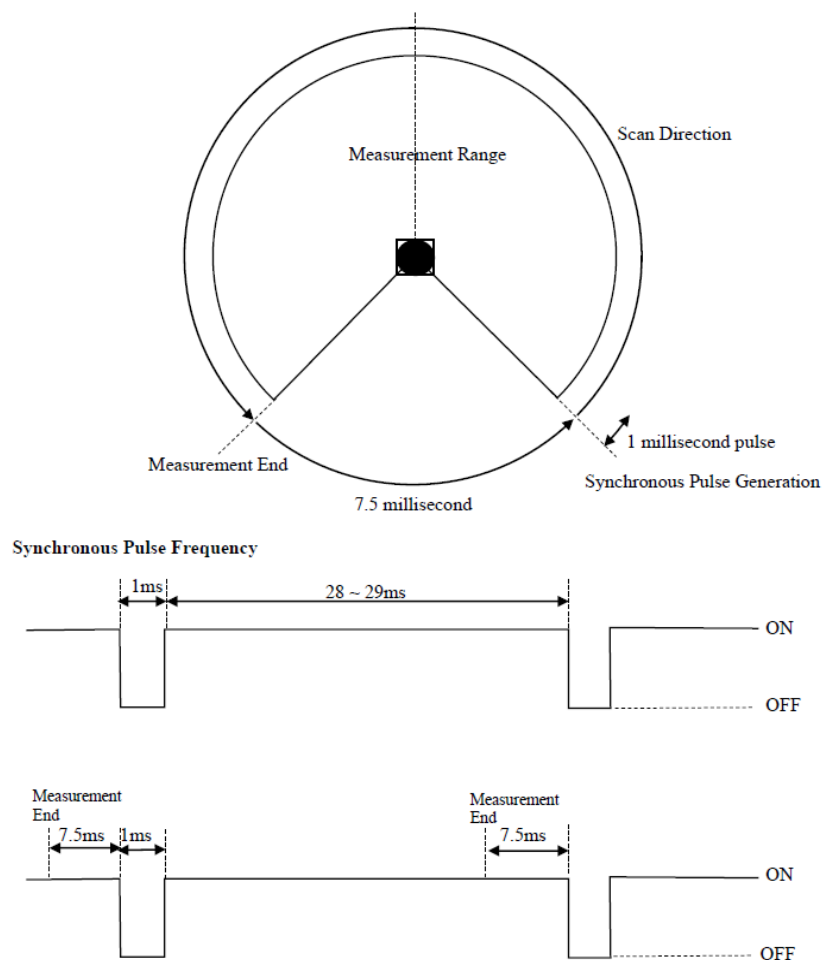

Note: Signal will be OFF when the device is in lockout state due to malfunction.

Title	Safety Laser Scanner UAM-05LPA-T301C Specification	Drawing No.	C-62-00056	39 / 44
-------	---	----------------	------------	---------

5. Wiring

5.1 Wire color and function

Table 5-1 shows the color of each lead wire, signal name and function. It is recommended to use the shielded cable for wiring.

Table 5-1 Wire color and function

Color	Signal	Function	Description	AWG
Brown	+ 24 DC	Power	Power Supply: DC 24V	22
Blue	0V DC	Power	Power Supply: DC 0V	22
Red	OSSD1	Output	Protection zone output 1	26
Yellow	OSSD2	Output	Protection zone output 2	26
Red/Black	WARNING 1/ OSSD3	Output	Warning zone output 1/Protection zone output 3	28
Yellow/Black	WARNING 2/ OSSD4	Output	Warning zone output 2/Protection zone output 4	28
Purple	IN_A	Input	Area switching Input A	28
Gray	IN_B / MUTING 3 / ENC3(4)_A	Input	Area switching Input B / Muting input 3 Encoder input 3(4)_A	28
White	IN_C / OVERRIDE1 / ENC1_A	Input	Area switching Input C/Override input 1/ Encoder input 1_A	28
Pink	IN_D / MUTING 1/ENC1_B	Input	Area switching Input D / Muting input 1/ Encoder input 1_B	28
Green	IN_E / EDM1 / ENC3(4)_A	Input	Area switching Input E /External device monitoring 1 / Encoder input 3(4)_A	28
Purple/Black	IN_A	Input	Area switching Input A invert	28
Gray/Black	IN_B / MUTING4 / ENC_3(4)_B	Input	Area switching Input B invert / Muting input 4 Encoder input 3(4)_B	28
White/Black	IN_C /OVERRIDE2 / ENC2_A	Input	Area switching Input C invert / Override input 2/Encoder input 2 A	28
Pink/Black	IN_D/ MUTING2 / ENC2_B	Input	Area switching Input D invert / Muting input 2 / Encoder input 2 B	28
Green/Black	IN_E / EDM2 / ENC3(4)_B	Input	Area switching Input E invert / External device monitoring 2 / Encoder input 3(4)_B	28
Yellow/Green	RESET 1 / ENC3(4)_A	Input	Reset input 1 / Encoder input 3(4)_A	28
Yellow/Blue	RESET 2 / ENC3(4)_B	Input	Reset input 2 / Encoder input 3(4)_B	28
Orange	RES_REQ1/MUT_OUT1/ AUX_OUT1	Output	RES_REQ1 : Request output 1 MUT_OUT1 : Muting state output 1 AUX_OUT1: Synchronous signal/Error/Window contamination error/Window contamination warning	28
Orange/Black	RES_REQ 2/MUT_OUT 2/ AUX_OUT2	Output	RES_REQ2 : Request output2 MUT_OUT2 : Muting state output2 AUX_OUT2: Synchronous signal/Error/Window contamination error/Window contamination warning	28
White/ Blue (TP)	RS485+	Communication	Communication protocol RS485	28
White/ Red (TP)	RS485-	Communication	Communication protocol RS485	28
Shield wire	FG	—	Frame ground	—

Title	Safety Laser Scanner UAM-05LPA-T301C Specification	Drawing No.	C-62-00056	40 / 44
-------	---	----------------	------------	---------

5.2 Wiring example

a) Standard (With maximum 32 sets of area)

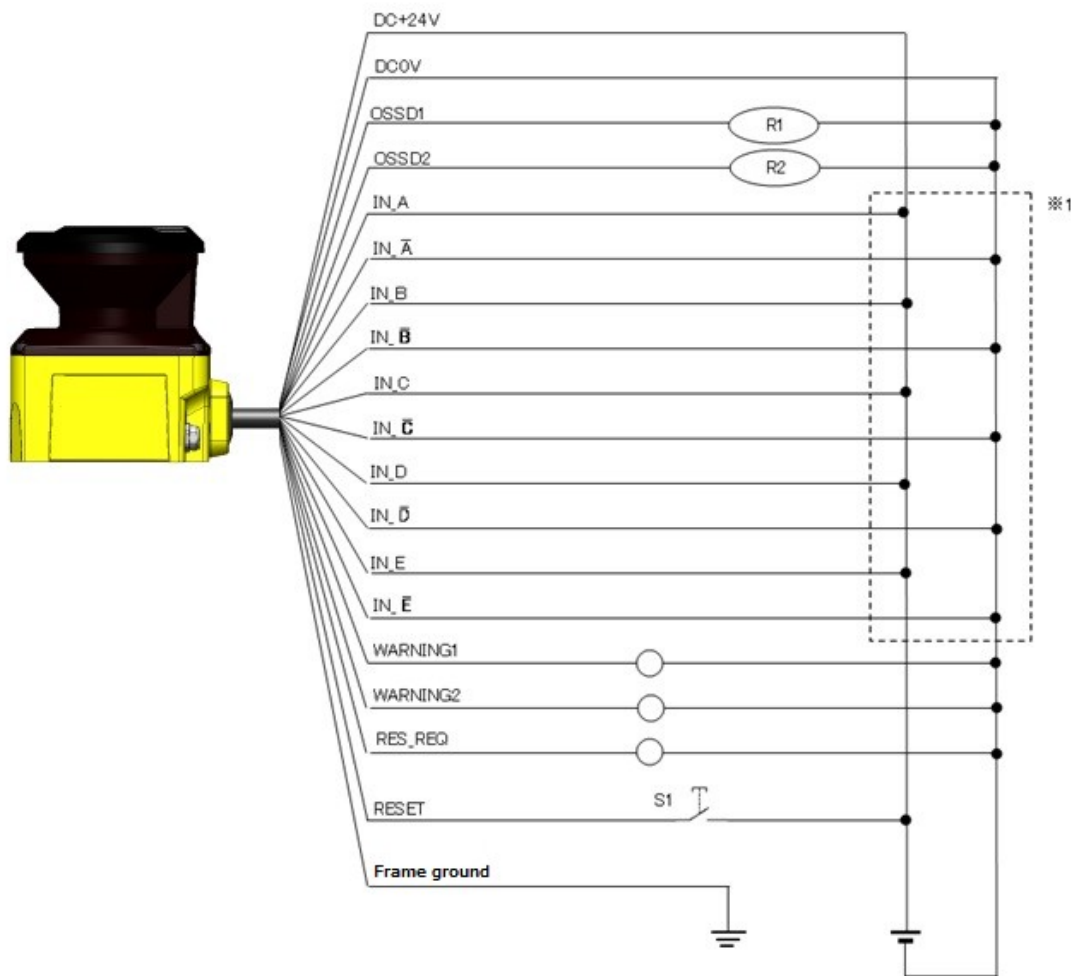

Figure 5-1 Wiring Example 1

R1 and R2: External equipment (Safety relay, Electromagnetic contactor)

S1: Interlock reset switch

*1: Refer to section 3.5 for the detail on area switching.

Title	Safety Laser Scanner UAM-05LPA-T301C Specification	Drawing No.	C-62-00056	41 / 44
-------	---	----------------	------------	---------

6. Input/ Output circuit

6.1 OSSD/ Warning Output circuit

OSSD/Warning output is output source type

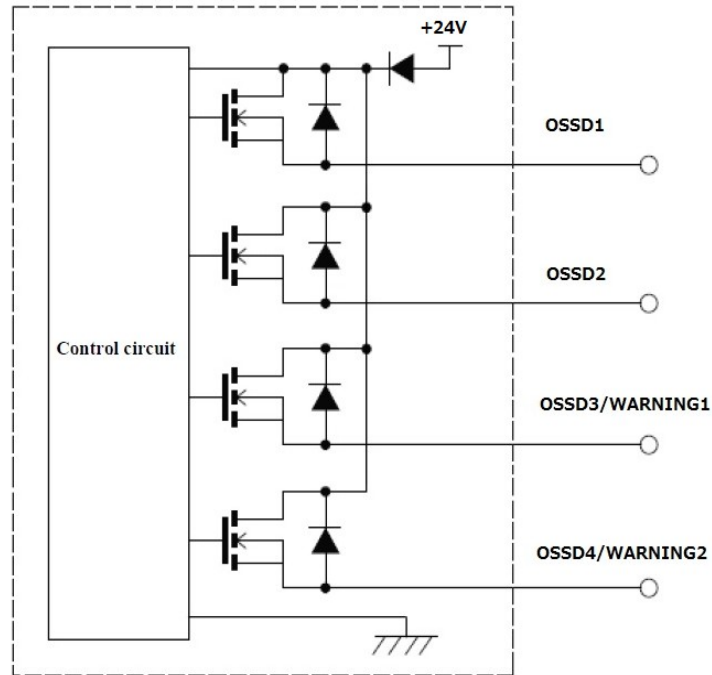

Figure 6-1 OSSD/WARNING Output circuit

6.2 Other output circuits

RES_REQ1, RES_REQ2, MUT_OUT1, MUT_OUT2, AUX_OUT1, AUX_OUT2 outputs are PNP type.

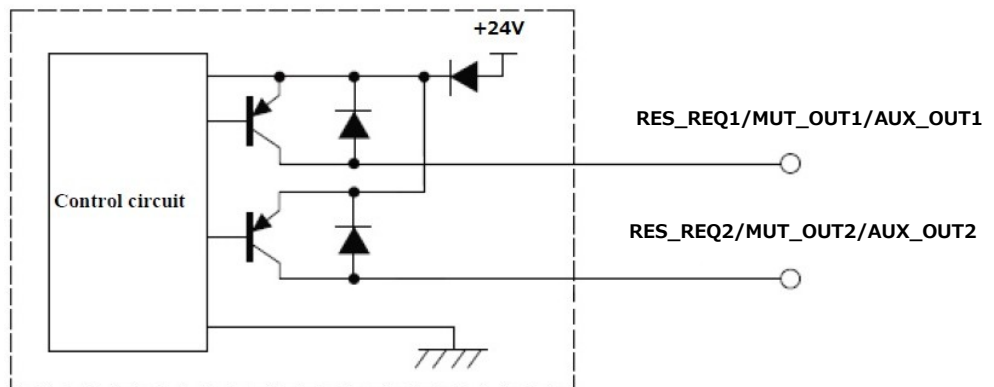

Figure 6-2 Output circuit

Title	Safety Laser Scanner UAM-05LPA-T301C Specification	Drawing No.	C-62-00056	42 / 44
-------	---	----------------	------------	---------

6.3 Input circuit

Figure 6-3 shows input circuit for Area input, EDM1, EDM2, RESET1, RESET2, MUTING 1, MUTING 2, MUTING 3, MUTING 4, OVERRIDE 1, and OVERRIDE 2 signals.

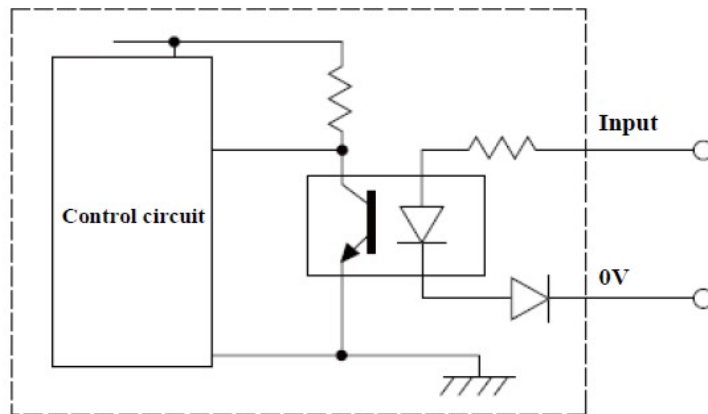

Figure 6-3 Input circuit

Title	Safety Laser Scanner UAM-05LPA-T301C Specification	Drawing No.	C-62-00056	43 / 44
-------	---	----------------	------------	---------

7. Revision history

Amended No.	Revision date	Details
-	November 2023	First Release
△	May 2024	• Compliance with UL Standard • Fixed input mode of area switchind added

Title	Safety Laser Scanner UAM-05LPA-T301C Specification	Drawing No.	C-62-00056	44 / 44
-------	---	----------------	------------	---------