

Smart-URG Eco

Scanning Laser Range Finder

UST-05LA



RoHS

1. General

Make sure to read carefully and understand this document (C-41-02490) while using the product.

1-1. Operation Principle

The UST-05LA is a scanning laser range finder. The sensor emits pulsed laser beams within a 270° field of view. When the emitted laser beams are reflected back from an object, its distance is measured by applying the Time-of-Flight (TOF) principle. The sensor has 541 measurement steps with a 0.5° pitch.

The user can preset up to 31 area patterns in the sensor. Each area has 3 outputs; Output 1, Output 2 and Output 3 (see Figure 1). When the sensor detects an object in the area, corresponding outputs are switched to an OFF state. User can obtain the measurement data from the sensor using SCIP communication protocol .

For details, refer to the SCIP communication protocol specification (document number C-42-4049).

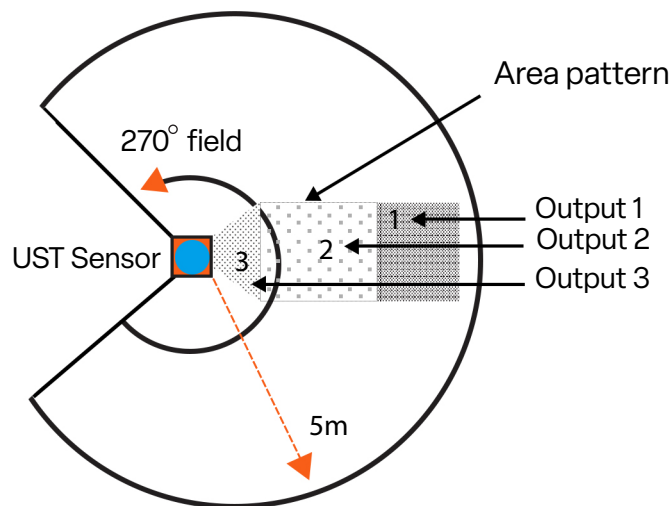

Figure. 1: Detection area and outputs in UST Sensor

1-2. Area configuration

The user can configure areas in the sensor using application software provided by the manufacturer. Install the software in a supported operating system and connect the sensor using a USB cable. See section 6 for details on types of area configuration.

1-3. Area switching

The sensor has 5 external inputs for switching the area. Provide the correct signal states on these inputs (see Table 1) to switch the area.

1-4. Malfunction output

The sensor has a self-diagnostic function. It switches the malfunction output to an OFF state when errors are detected in the internal components.

1-5. Synchronous operation

The sensor has a scanner synchronization function to avoid mutual interference between multiple sensors. To use this function connect the Synchronous Output of one sensor (master) to the Synchronous Input of the other (slave). The slave sensor adjusts its scanner position with a preset time lag from the master. The time lag can be specified using the application software.

1-6. Hysteresis of detection area

When objects are present on the boundary of an area, sensor may not detect them continuously. In such cases, the output signals oscillate frequently between the ON and the OFF states. Sensor has hysteresis function that temporarily increases the area size to prevent such oscillation. Ratio of increase can be specified using the application software.

1-7. Log function

The sensor logs the measurement data and the output states during the operation. The logged data can be obtained for verification using the application software. Number of logs is limited due to the size of internal memory.

1-8. Communication Interface

The sensor is equipped with both USB and RS422 communication interfaces. It is possible to configure areas and write them in the sensor by using application software via these interfaces. The sensor also supports SCIP protocol, therefore, user can obtain measurement data by sending commands of this protocol.

2. Structure

2-1. Structure Diagram

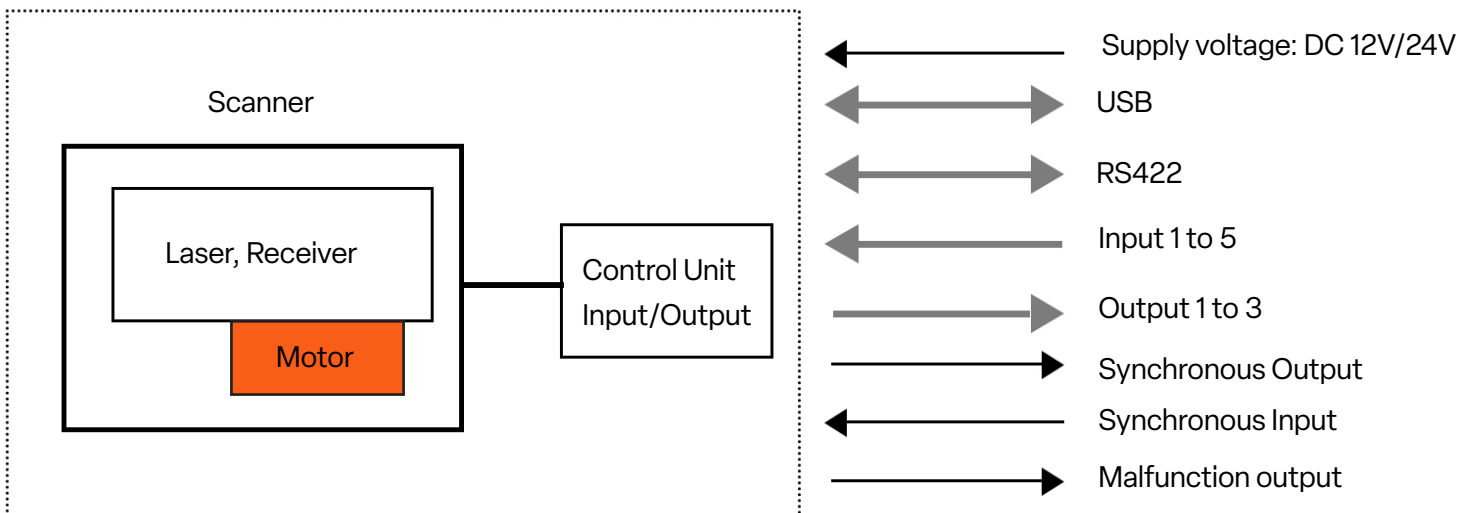

Figure. 2: Structure diagram

UST-05LA



3. Product Specs

Product Name	Scanning Laser Range Finder	
Model	UST-05LA	
Supply voltage	DC 12V/DC 24V (operation range 10 to 30V, ripple within 10%)	
Supply current	150mA(DC 24V) or less (during start up about 400mA is necessary.)	
Light source	Laser semiconductor (905nm), Laser class 1 (IEC60825-1:2007, Accession number:1420210-000)	
Detection range and object	60mm to 5000mm (white Kent sheet) 60mm to 2000mm (diffuse reflectance 10%) Minimum detectable size 130mm (changes according to distance) *1	
Accuracy	60mm to 5000mm $\pm 40\text{mm}^2$	
Standard deviation	$\sigma < 20\text{mm}^2$	
Scan angle	270°	
Scan speed	25ms (motor speed 2400rpm)	
Angular resolution	0.5°	
Start up time	Within 10 sec (start up time differs if malfunction is detected during start up)	
Outputs	Photo-coupler, open collector output Max DC 30V 50mA Output 1: Output 1 OFF during object detection Output 2: Output 2 OFF during object detection Output 3: Output 3 OFF during object detection Malfunction output: ON during normal operation, OFF during malfunction Synchronization output: Synchronization signal during Master/Slave operation. Note: Output 1 to 3 are switched OFF during malfunction state	
Inputs	Photo-coupler, common anode, power supply is 4mA when input is ON Input 1 to 5: Area switching inputs (refer Table1) Synchronization input: Input synchronization signal during Slave operation.	
Output Response Time *3	OFF	66msec to 3241msec
	ON	66msec to 3241msec
Hysteresis	Hysteresis high (6.25%) Hysteresis low (3.125%) No Hysteresis (Default)	
Interface	USB / RS422	
LED display	Blue LED: ON during normal operation, blink during the start up, configuration and malfunction state Orange LED 1: Output 1 ON during object detection Orange LED 2: Output 2 ON during object detection Orange LED 3: Output 3 ON during object detection	
Synchronization function	Synchronization Master/Slave operation mode (can set by using Area Designer) *4 Synchronization slave mode (0°) Synchronization slave mode (90°) Synchronization slave mode (180°) Synchronization slave mode (270°)	

*1 In the case of installing the sensor parallel to the Emitter/Receiver surface. Minimum detectable size of the object can be set by Area Designer.

*2 Under the factory standard testing condition using white Kent sheet.

*3 Initial setting is 66msec. ON/OFF delay function switching is possible by Area Designer. Response time can be further delayed by a maximum of 1 scan during the area switching.

*4 Initial setting is synchronization master. When using synchronization operation, refer to section 5.3 for details about synchronization wiring. Synchronization slave setting is possible using Area Designer.



UST-05LA

Surrounding intensity	Less than 80,000lx Note : Avoid direct sunlight or other illumination sources as it may cause sensor malfunction
Ambient temperature humidity	-10°C to +50°C, below 85%RH (without dew, frost)
Storage temperature humidity	-30°C to +70°C, below 85%RH (without dew, frost)
Vibration resistance	10 to 55Hz double amplitude of 1.5mm for 2hrs in each X, Y, and Z direction 55 to 200Hz 98m / s ² sweep of 2min for 1hr in each X,Y and Z direction
Shock resistance	196m/s ² (20G) X,Y and Z direction 10 times.
Insulation resistance	10MΩ, DC 500V
Log function *5	Can record distance, level data, etc., of each step
Protective structure	IP65
EMC standards	(EMI) EN61326-1:2013 EN55011:2009 + A1:2010 (EMS) EN61326-1:2013 EN61000-4-2:2009 EN61000-4-3:2006 + A1:2008 + A2:2010 EN61000-4-4:2012 EN61000-4-6:2009 EN61000-4-8:2010
Weight	130g
Material	Front case: Polycarbonate, Rear case: Aluminum
Dimensions (W×D×H)	50×50×70mm

*5 The recorded distance data, level data, etc., can be confirmed using Area Designer application.

Table 1: Input states and corresponding area number

[Input 1]	[Input 2]	[Input 3]	[Input 4]	[Input 5]	Area Number
ON	ON	ON	ON	ON	Laser off*1
OFF	ON	ON	ON	ON	Area 1
ON	OFF	ON	ON	ON	Area 2
OFF	OFF	ON	ON	ON	Area 3
ON	ON	OFF	ON	ON	Area 4
OFF	ON	OFF	ON	ON	Area 5
ON	OFF	OFF	ON	ON	Area 6
OFF	OFF	OFF	ON	ON	Area 7
ON	ON	ON	OFF	ON	Area 8
OFF	ON	ON	OFF	ON	Area 9
ON	OFF	ON	OFF	ON	Area 10
OFF	OFF	ON	OFF	ON	Area 11
ON	ON	OFF	OFF	ON	Area 12
OFF	ON	OFF	OFF	ON	Area 13
ON	OFF	OFF	OFF	ON	Area 14
OFF	OFF	OFF	OFF	ON	Area 15
ON	ON	ON	ON	OFF	Area 16
OFF	ON	ON	ON	OFF	Area 17
ON	OFF	ON	ON	OFF	Area 18
OFF	OFF	ON	ON	OFF	Area 19
ON	ON	OFF	ON	OFF	Area 20
OFF	ON	OFF	ON	OFF	Area 21
ON	OFF	OFF	ON	OFF	Area 22
OFF	OFF	OFF	ON	OFF	Area 23
ON	ON	ON	OFF	OFF	Area 24
OFF	ON	ON	OFF	OFF	Area 25
ON	OFF	ON	OFF	OFF	Area 26
OFF	OFF	ON	OFF	OFF	Area 27
ON	ON	OFF	OFF	OFF	Area 28
OFF	ON	OFF	OFF	OFF	Area 29
ON	OFF	OFF	OFF	OFF	Area 30
OFF	OFF	OFF	OFF	OFF	Area 31

*1 Laser is switched off when all inputs (1 to 5) are ON.

4. Connection

4-1. Power source, I/O Cable

Cable Length: 1000mm flying lead

Color	Signal
Brown	+VIN (DC12V/DC24V)
Blue	-VIN
Black	Output 1
White	Output 2
White (Blue)	Output 3
Orange	Malfunction Output
Light Green	Synchronous Output
Gray	COM Output -
Red	COM Input +
Green	Input 1
Yellow	Input 2
Purple	Input 3
White (Black)	Input 4
White (Red)	Input 5
Light Blue	Synchronous Input
Pink	RS422 GND
Yellow (Red)	RS422 TXD+
Yellow (Black)	RS422 TXD -
Light Blue (Red)	RS422 RXD+
Light Blue (Black)	RS422 RXD -

Note 1: Input/Output direction is mentioned from the sensor's side.

Note 2: Colors inside the bracket indicates dual color cable.

Note 3: Keep the input wires open or connect to input Com+ if not in use.

Note 4: Keep the output wires open or connect to output Com- if not in use.

5. LED Display

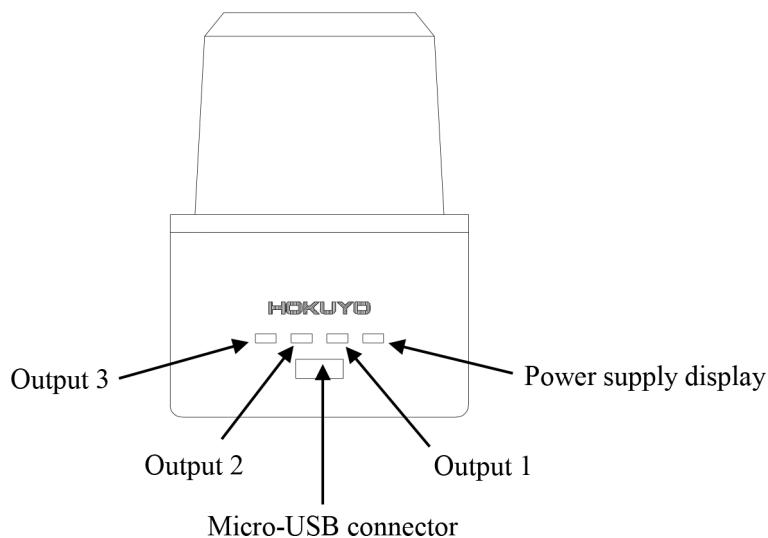

6. Area configuration

It is possible to configure two types of area in the sensor.

1. Normal configuration
2. Independent configuration

6-1 Normal configuration

In the normal configuration, the area for Output 1 is configured first and the shape of it can be configured freely. Areas for Output 2 and Output 3 are dependent on the set area of Output 1 and therefore they are configured inside it. The shapes of Output 2 and Output 3 areas can be straight, fan shape or ratio (Figure 3). Figure 4 and Table 2 show the relationship between the detected object position and the output states.

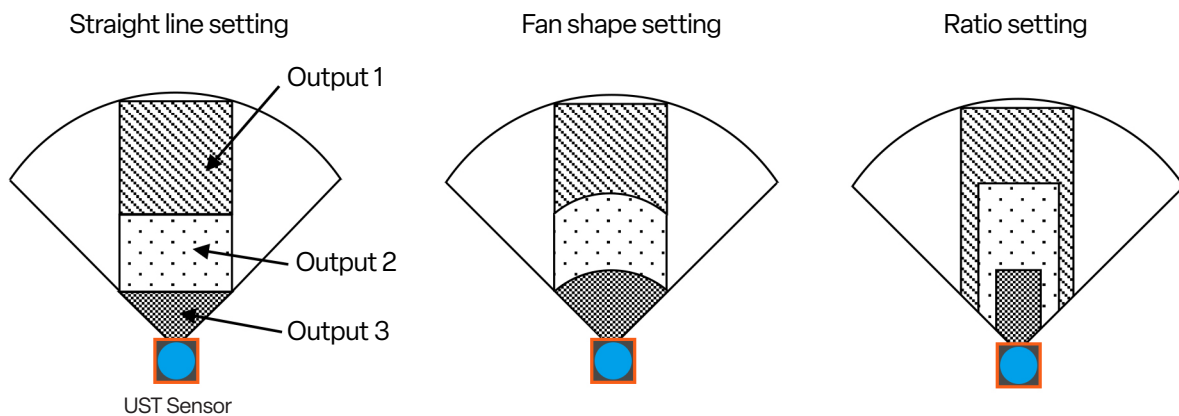

Figure 3: Normal area configuration

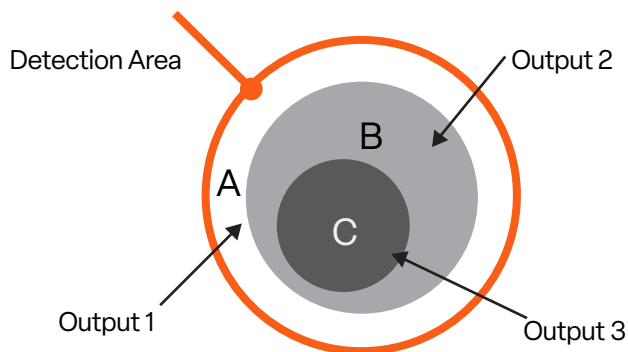

Figure 4: Output Areas

Object Position	Output 1	Output 2	Output 3
A	OFF	ON	ON
B	OFF	OFF	ON
C	OFF	OFF	OFF

Table 2: Relationship between object position and output states

6-2. Independent configuration

In the independent configuration, areas for Output 1, Output 2 and Output 3 can be configured freely. The field covered by each output can be completely separate from the other output areas or there can be an overlapping region between the output areas Figure 5 (a) and (b). Figure 6 and Table 3 show the relationship between the object position and the output states.

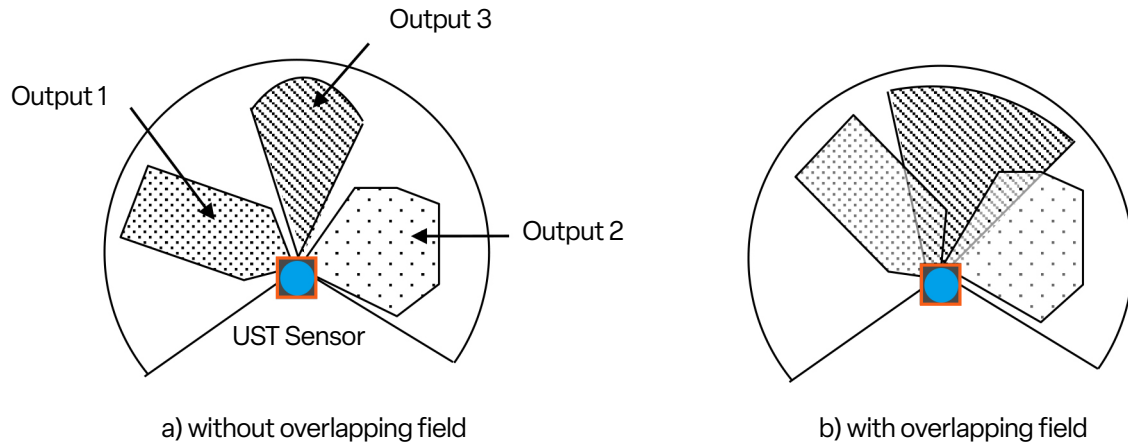

Figure 5: Independent area configuration

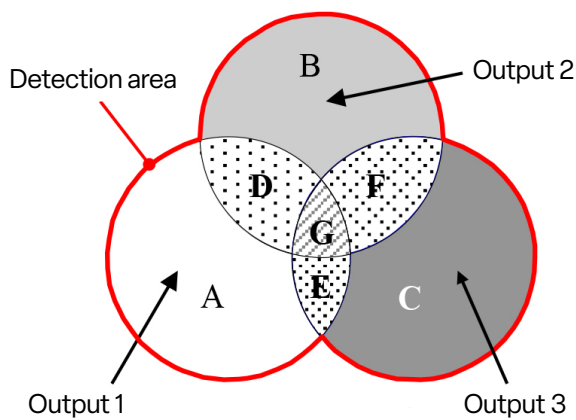

Figure 6: Output areas

Object Position	Output 1	Output 2	Output 3
A	OFF	ON	ON
B	ON	OFF	ON
C	ON	ON	OFF
D	OFF	OFF	ON
E	OFF	ON	OFF
F	ON	OFF	OFF
G	OFF	OFF	OFF

Table 3: Relationship between object position and output area

7. Input/Output circuit connection example

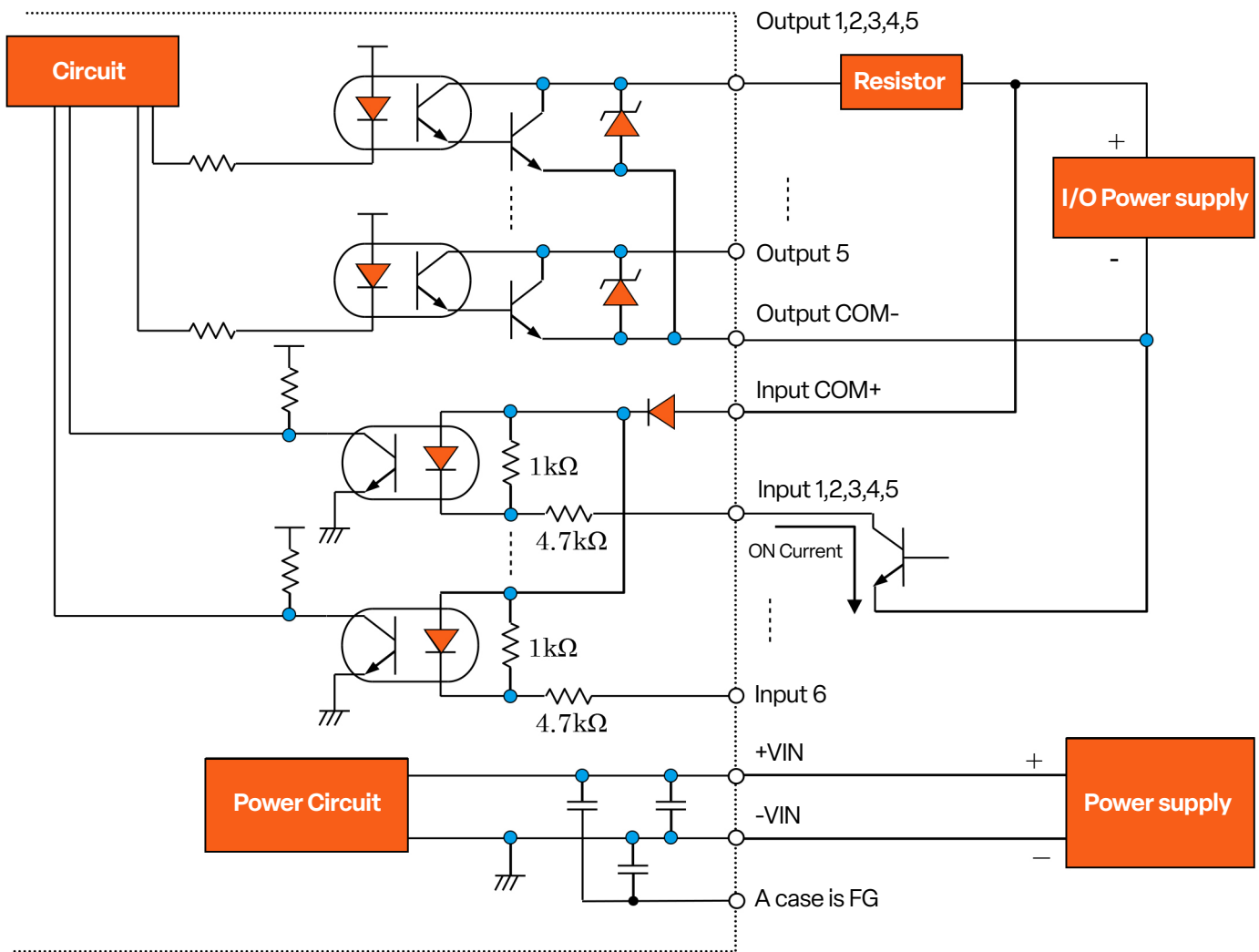
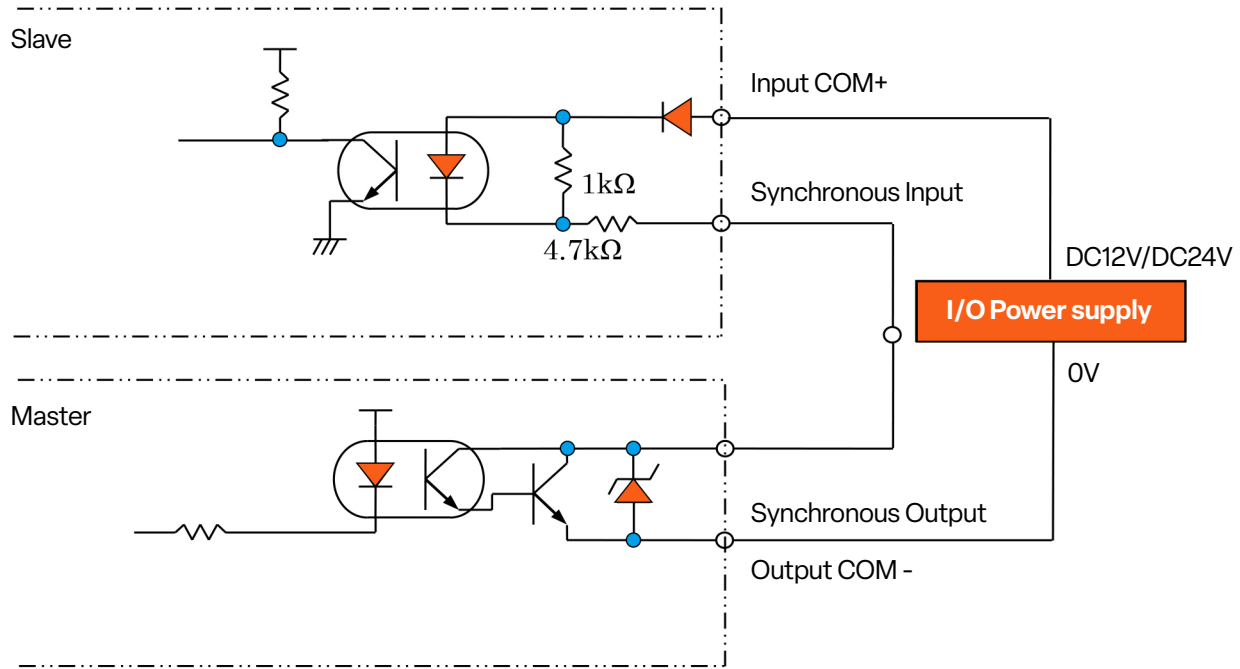

Figure 7: Connection example of inputs, outputs and power supply.

8. The example of synchronous wiring

Synchronous Output (master) : Light green

Synchronous Input (slave) : Light Blue





ISO14001 Certified
JQA-EM3873



ISO9001 Certified
JQA-1742

- Read instruction manual carefully before use.
- Products published in this brochure are intended to be used under specific conditions.
- For product related questions or technical issues, please contact our offices.



HOKUYO AUTOMATIC CO.,LTD.

Higobashi Union Building, 1-9-6 Edobori, Nishi-ku,
Osaka-shi, Osaka, 550-0002 Japan
TEL: +81-6-6441-2239 FAX: +81-6-6441-2204
URL: <http://www.hokuyo-aut.jp>
E-mail: info@hokuyo-aut.jp

● EUROPE

HOKUYO AUTOMATIC CO., LTD. Amsterdam Branch
Prof. J.H. Bavincklaan 2, 1183 AT Amstelveen, The Netherlands
TEL: +31-20-240-0110
E-mail: info@hokuyo-aut.jp

● AMERICA

Hokuyo Automatic USA Corporation
2019 Van Buren Ave. Suite A, Indian Trail, North Carolina 28079 U.S.A.
TEL: +1-704-882-3844
E-mail: sales@hokuyo-usa.com

● KOREA

HOKUYO KOREA CO., LTD.
104-211, 397 Seokcheon-Ro, Ojeong-Gu, Bucheon-City, Korea
TEL: +82-32-624-3194
E-mail: hokuyokorea@naver.com