

Laser Range Finder

Scanning Laser Range Finder

UXM-30LAH-EHA





RoHS

1. General

Operation principle

- UXM 30LAH-EHA is a sensor which scans a semicircular field by means of a laser beam ($\lambda = 905 \text{ nm}$), then calculates coordinates by measuring the distance from an object and its step angle, and detects obstacles within the setting area.
- Distance data can be obtained using communication protocol SCIP from the sensor
- Safety of the laser is class 1.
- By using the motor rotation synchronization function from an outside reference signal, the influence of interference between multiple units can be eliminated.
- By enabling the built-in heater function through the application software, condensation can be eliminated.
- The “detached area setting” allows to configure the area which is away from the sensor.

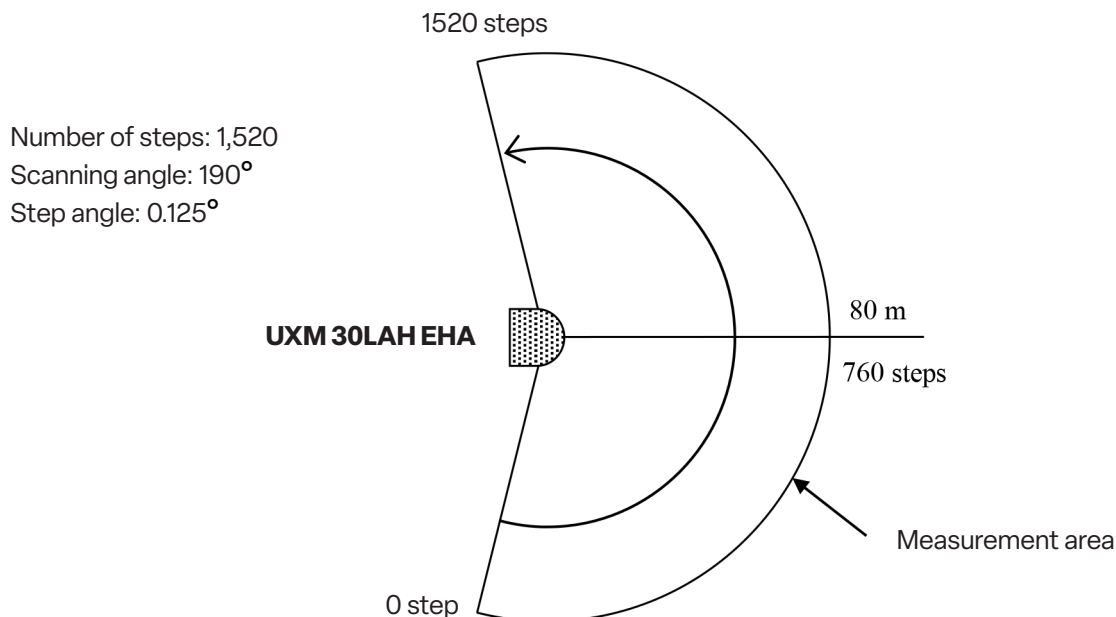
2. Configuration (beam scan image)



3. Disclaimer

- This sensor is not certified for the functional safety.
- This sensor cannot be used for human body detection as per the machinery directives.
- Sensor emits laser for measurement. Sensor’s operation may become unstable under the influence of strong interference light or when emitted lights are not reflected back from the object.
- Sensor’s operation may become unstable due to rain, snow and fog or due to dust pollution on the optical window.
- Rules and regulations related to safety should be strictly followed when operating the sensor.
- When there is a risk that this sensor is used for mass destruction weapons, weapons and equipment aimed at killing human beings, and relevant technologies, etc., or when its usage for those purposes has become clear, sales may be prohibited in accordance with the Foreign Exchange and Foreign Trade Act, and the Export Trade Control Order (Japanese law). Moreover, regarding export of products, the formalities according to laws/Export Trade Control Order are implemented in order to maintain international peace and safety.
- Before using the sensor, please read this specification.

4. Rated specification

Product Name	Laser range finder
Model	UXM-30LAH-EHA
Light source	Semiconductor laser, $\lambda = 905 \text{ nm}$, Laser class 1 (FDA)
Power supply voltage	10 to 30VDC
Power supply current	Steady-state current: 600 mA or less at 12 VDC, 300 mA or less at 24 VDC Starting current: 1.5 A or less at 12 VDC, 0.75 A or less at 24 VDC Heater in use (0°C or below): 1.25 A or less at 12 VDC, 1.25 A or less at 24 VDC
Electric power consumption	7.2 W or less (at steady-state) Heater in use(0°C or below): 15 W or less at 12 VDC, 30 W or less at 24 VDC
Detection range and object	Guaranteed value of detection: 0.1 to 30 m*1 (Reflectance of 10%, black paper, 500 mm × 500 mm) 0.1 to 80 m*1 (Reflectance of 90%, white Kent paper, 1,000 mm × 1,500 mm) Maximum detecting distance: 80 m (maximum value of area setting) Minimum object to be detected : 33 mm (5 m), 65 mm (10 m), 200 mm (30 m)
Average Accuracy by distance	10% reflectance, black paper, 0.1 to 15 m: $\pm 30 \text{ mm}^1$ 0.1 to 30 m: $\pm 50 \text{ mm}^2$ Ambient illuminance: 3,000 lux or less 0.1 to 20 m: $\pm 50 \text{ mm}^2$ Ambient illuminance: 100,000 lux or less
	90% reflectance, white Kent paper, 0.1 to 30 m: $\pm 30 \text{ mm}^1$ 0.1 to 30 m: $\pm 50 \text{ mm}^2$ Ambient illuminance: 3,000 lux or less 0.1 to 30 m: $\pm 50 \text{ mm}^2$ Ambient illuminance: 100,000 lux or less
Measurement	Unit of 1 mm
Repeat accuracy	110% reflectance, black paper, 0.1 to 15 m: $\sigma < 10 \text{ mm}$, 15 to 30 m: $\sigma < 15 \text{ mm}^1$ 0.1 to 30 m: $\sigma < 20 \text{ mm}^2$ Ambient illuminance: 3,000 lux or less 0.1 to 20 m: $\sigma < 30 \text{ mm}^2$ Ambient illuminance: 100,000 lux or less
	90% reflectance, white Kent paper, 0.1 to 30 m: $\sigma < 10 \text{ mm}^1$ 0.1 to 30 m: $\sigma < 15 \text{ mm}^2$ Ambient illuminance: 3,000 lux or less 0.1 to 30 m: $\sigma < 30 \text{ mm}^2$ Ambient illuminance: 100,000 lux or less
Scanning angle	190°
Angular resolution	Approx. 0.125° (360°/2880 divisions)
Scanning time	50 ms (rotating speed of motor: 1200 rpm)
Interface	Ethernet 100BASE-TX (Auto-negotiation)
Output	OUTPUT 6 points: Synchronization master output, Synchronization output, Malfunction output, Detection output 1 to 3
Input	INPUT 5 points: Synchronization input, Area input 1 to 4(total 15 patterns)
Output response time	100ms or less;however,it varies depending on the setting
Starting time	Operation starts within 30 sec after turning on of power supply.
Indication lamp	Indication lamp for power supply and operation (green), indication lamp for area determination (orange) Regarding the operation of indication lamps, refer to sub-clause 7.2.
Ambient operating temperature, humidity	I-10 to +50°C 85%RH -30 to +50°C 85%RH (Heater in use) ✕ However, dew condensation and freezing should not exist.
Environmental	Detecting distance becomes shorter due to rain, snow, and sunlight.* ³
Vibration resistance	10 to 55 Hz, plural amplitude: 1.5 mm in X, Y, Z directions, each 2 hours 55 to 200 Hz 196 m/s ² Sweep: 2 minutes in X, Y, Z directions, each 1 hour
Resistance to shock	196 m/s ² in X, Y, Z directions, each 10 times

Notes *¹Indoor environment (fluorescent lamp, 1,000 lux or less)

*²Detection cannot be guaranteed when direct light (such as sunlight) enters the device.

*³Regarding the influence of environment, please confirm with the actual equipment.

4. Rated specification (Continued)

Item	Specification
EMC standards	(EMI) EN61326-1:2013 EN55011:2009 + A1:2010 (EMS) EN61326-1:2013 EN61000-4-2:2009 EN61000-4-3:2006 + A1:2008 + A2:2010 EN61000-4-4:2012 EN61000-4-6:2014 EN61000-4-8:2010
Protective structure	IP67
Insulation resistance	10 MΩ
Weight	Approximately 1200g (with cable)
Material	Front face of the case: AES, Optical window: Polycarbonate, Back face of the case: Aluminum
External Dimension (W × D × H)	124 mm × 126 mm × 150 mm (connector not included) Outline drawing No.: MC-40-3340

5. Connection

5.1 Specification of power cables

Power cable, 16 cores, 2 m (specification of flying lead)

Cable Color	Function	Size of cable core(AWG)
Brown	+V (10 to 30 V)	22
Blue	-V (0 V)	22
White/Red	Area Input 1	28
White/Blue	Area Input 2	28
White/Green	Area Input 3	28
White/Black	Area Input 4	28
White	Synchronization input	28
Orange	Malfunction output	28
Pink	Detection output 1	28
Violet	Detection output 2	28
Yellow/Black	Detection output 3	28
Green	Synchronization output	28
Yellow	Synchronization master output	28
Red	+COM for input	28
Black	-COM for output	28
Gray	NC ^{*4}	28
Shield	FG	-

Notes ^{*4} There is internal connection. Do not connect because it is not used.

5.2 Specification of the interface connector

Sensor side

Maker: Binder
Type: 09-0431-87-04

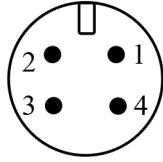

Ethernet connecting plug (Option)

Straight type plug (Binder, 99-0430-57-04)
Type L plug (Binder, 99-0430-69-04)

PIN No.	Function	Wiring color (T568A)
1	TX+	White/Green
2	TX-	Green
3	RX+	White/Orange
4	RX-	Orange

RJ-45 modular wiring example

PIN No.	Wiring color	
	Straight	Cross
1	White/Green	White/Orange
2	Green	Orange
3	White/Orange	White/Green
4	Blue	Blue
5	White/Blue	White/Blue
6	Orange	Green
7	White/Brown	White/Brown
8	Brown	Brown

For the details on the communication protocol, refer to the Communication specification (C-42-04041).

5.3 Input/output circuit

Input: Photocoupler input (common anode, current to turn on each input: 2 mA or more, current to turn off each input: 0.5 mA or less)

Output: Open collector output.

Item	Specification
Maximum output current	50 mA
Maximum applied voltage	30 V
Output residual voltage	1V or less
Power supply range at +COM	10 to 30 V

Example of connecting the input/output circuit

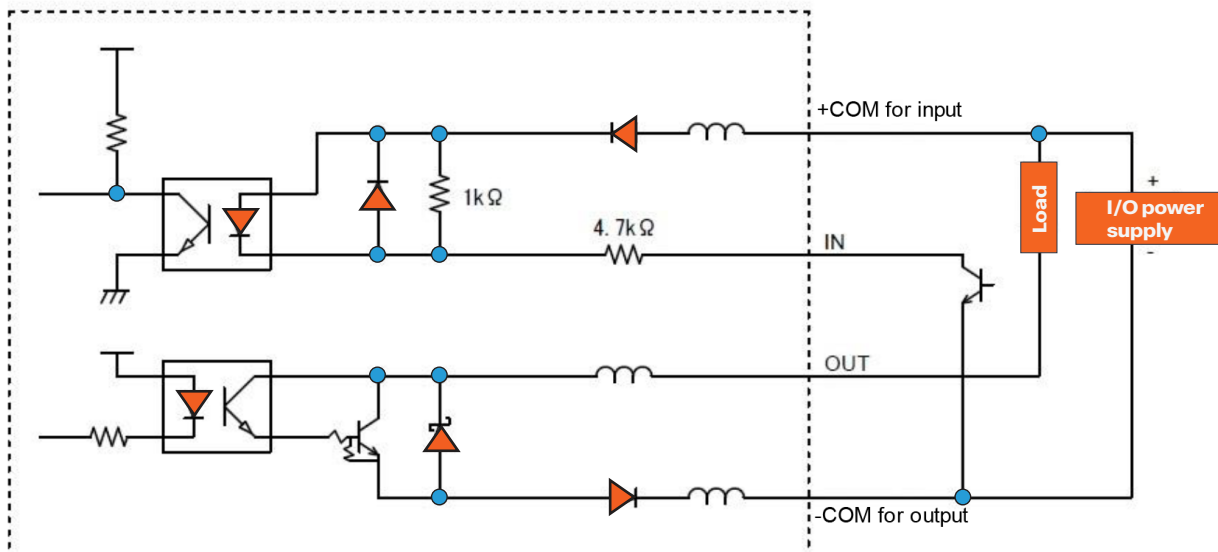

6. Control signal

6.1 Malfunction Output

(1) Laser malfunction : When the laser does not emit a beam or exceeds the safety class 1.

(2) Motor malfunction : When rotation speed of the motor is not within 1,200 rpm

Sensor's outputs will switch to OFF state, laser is turned OFF and motor is stopped on malfunction detection. Check the error code via Ethernet. Error details and troubleshooting measure are shown in Table meaning and handling methods for each error code can be found in Section 7.

6.2 Synchronization output

Sensor outputs a 1 ms pulse in every scan which is synchronized with the scanning. The timing of the synchronization signal is shown in the figure below.

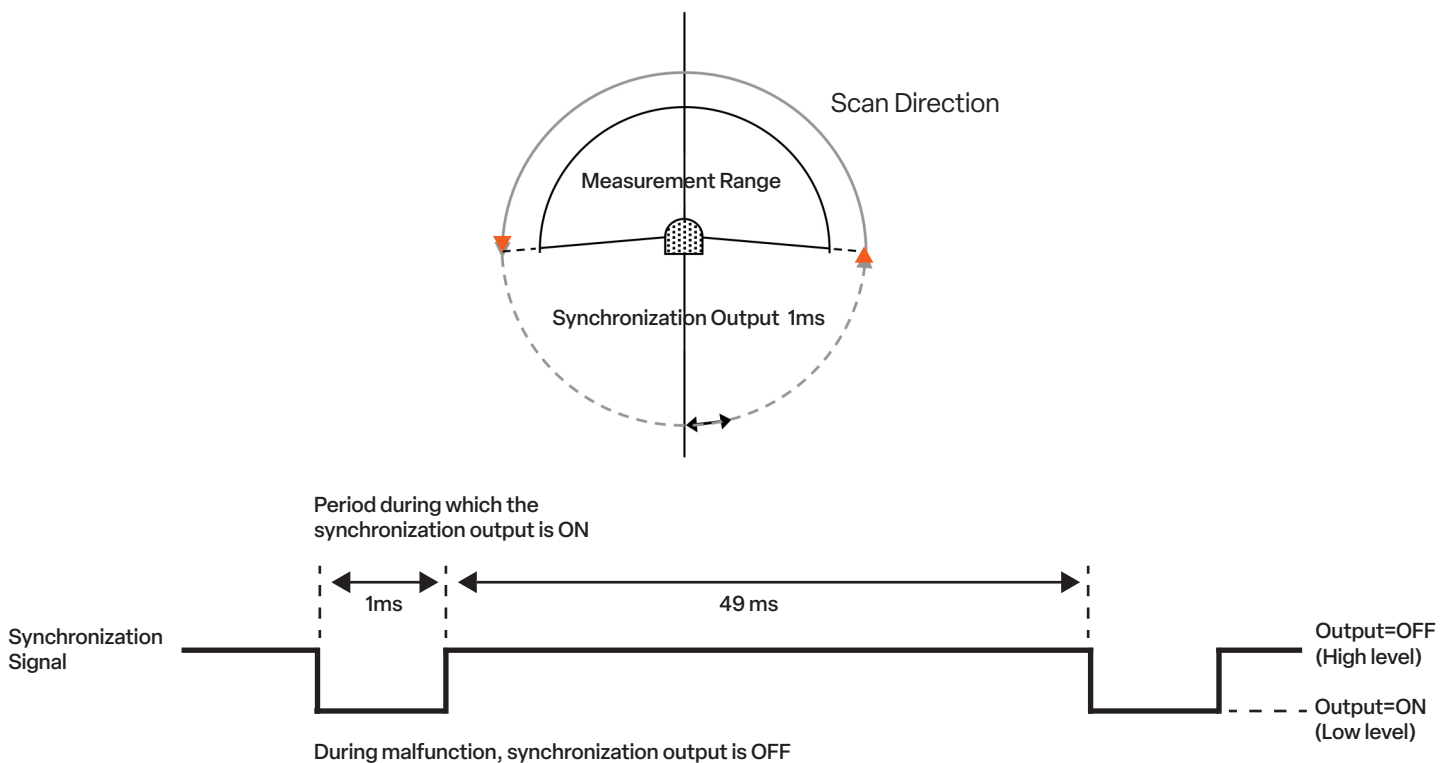

6.3 Synchronization master output

It is a reference clock signal for synchronizing the motor rotation.

The clock signal cycle is 50 ms and the period during which the output is ON (Low level) is 12.5 ms.

(Duty: 25%).

Signal is generated just after turning on the power supply of the sensor and it is continued even in the failed state. Refer section 6.5 and 6.6 for further details.

6.4 Synchronization input

It is a reference clock signal received from the master sensor for synchronizing the motor rotation.

Motor rotation of the slave sensor is controlled to synchronize with the master sensor. Synchronization is performed with the falling edge of the clock signal. Refer section 6.5 and 6.6 for further details.

6.5 Example of wiring between sensors for motor rotation synchronization

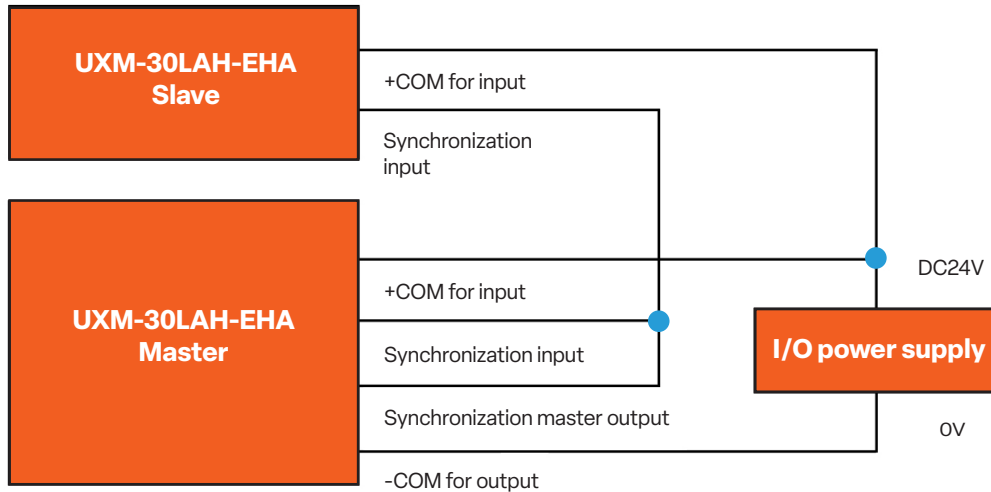

Synchronization output of the master sensor is connected to the synchronization input of the master itself and to the synchronization input of all slave sensors.

Motor rotation of each slave is shifted by a phase defined during the sensor setting. Configuration and change of the phases are performed by means of the dedicated application program.

6.6 Timing chart of synchronization input/output

- When synchronization master output of the master is not connected to the synchronization input of the slave. Synchronization output of each sensor has a cycle of 50 ms with the signal at low level for 1 ms.

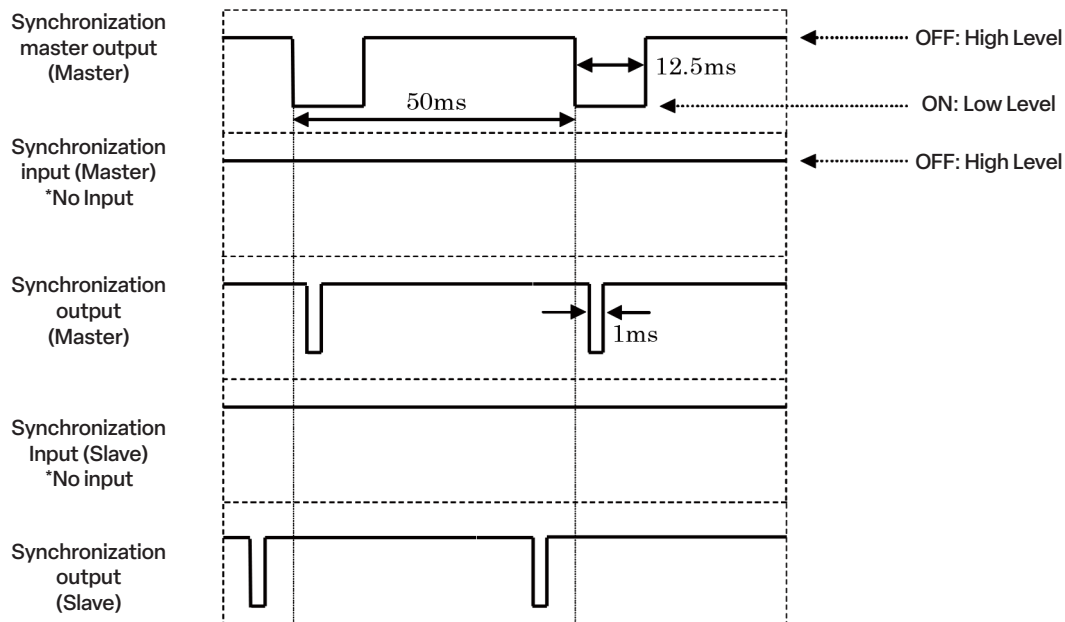

- When synchronization master output of the master is connected to the synchronization input of the slave Falling edge of the synchronization master output signal and falling edge of the synchronization output signal which are connected to synchronization input of the slave are synchronized. Based on the phase setting performed by means of the application program, the motor rotation of the slave is shifted by the setting amount. Error of phase setting shall be within ± 1 ms.

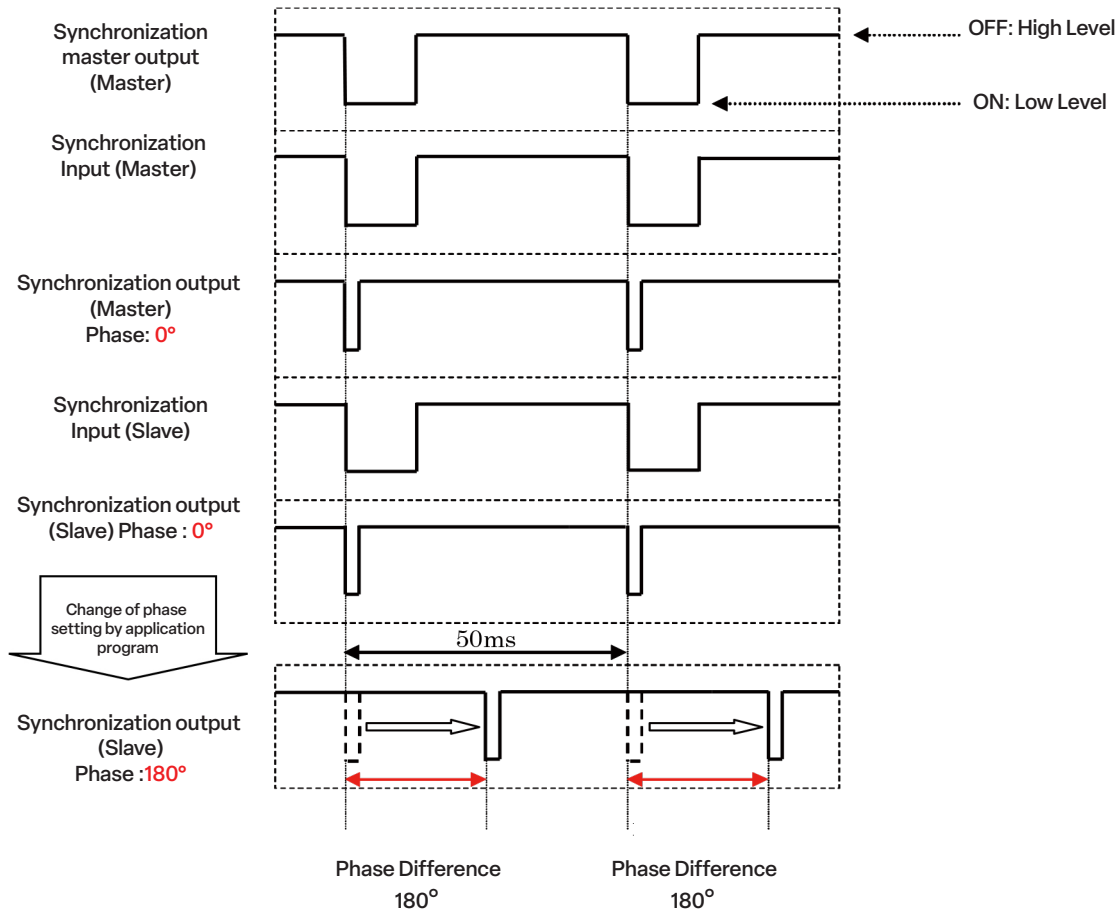

6.7 Area input and selection area set

Setting of three regions is possible in one area set, and respectively corresponds to output 1, output 2, and output 3. Selection of the area number is performed by means of the area inputs, IN 1 to 4. However, when all of the area inputs (IN 1 to 4) are ON (low level), the sensor switches to emission stop mode.

OFF: High level, ON: Low level

Response time of input: Time for 2 scans (100 ms)

Area input 1	Area Input 2	Area Input 3	Area Input 4	Area Set
ON	ON	ON	ON	Stop emission
OFF	ON	ON	ON	Area 1
ON	OFF	ON	ON	Area 2
OFF	OFF	ON	ON	Area 3
ON	ON	OFF	ON	Area 4
OFF	ON	OFF	ON	Area 5
ON	OFF	OFF	ON	Area 6
OFF	OFF	OFF	ON	Area 7
ON	ON	ON	OFF	Area 8
OFF	ON	ON	OFF	Area 9
ON	OFF	ON	OFF	Area 10
OFF	OFF	ON	OFF	Area 11
ON	ON	OFF	OFF	Area 12
OFF	ON	OFF	OFF	Area 13
ON	OFF	OFF	OFF	Area 14
OFF	OFF	OFF	OFF	Area 15

6.8 Example of Detection output

Example of output state when the object is present at the positions A, B, C of the sample area is shown in the table below.

Position of object to be detected	Detection output 1	Detection output 2	Detection output 3
A	ON	ON	OFF
B	ON	OFF	OFF
C	OFF	OFF	OFF

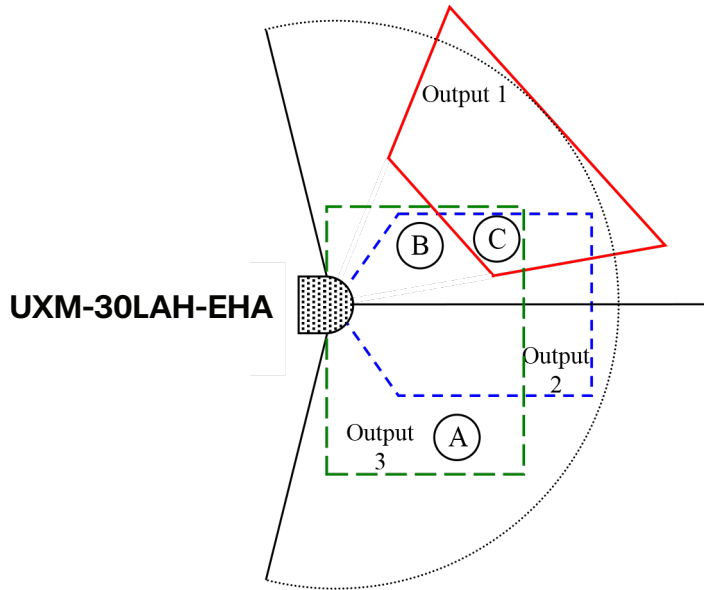

7. Sensor failure and handling method

7.1 Error code table

The cause of an error can be obtained from STAT line of the II Command response, in the SCIP communication protocol.

The error codes and solution from the STAT line are as follows.

ID	Message	Meaning	Solution
000	no error.	Normal operation	No action is required
050	internal chip access failed.	Sensor processing system error	Sensor has failed and needs to be repaired
100	internal chip access failed.	Same as above	
150	internal chip access failed.	Same as above	
151	internal chip initialize failed.	Sensor processing system initialization failure	
200	encoder error.	Encoder fault	Reduce the vibration and noise to the sensor.
250	motor startup failed.	Motor fault	
251	motor rotation error.	Unstable motor rotation	
300	laser too high.	Laser fault	Reduce the ambient light and noise to the sensor.
301	laser too low.	Same as above	
302	laser no echo	Same as above	
303	measurement error.	Measuring data processing fault	Reduce the vibration, ambient light and noise to the sensor

About distance value

Meaning of the measured distance value x at each step are as follows.

Range of the distance value	Meaning
$x < 23$	Measurement error. Distance cannot be measured due to the influence of interfering light and noise.
$23 \leq x < 120000$	Measured distance value [mm]
$120000 \leq x$	There is a no object or nondetectable object

7.2 Relation table between indication lamps and output signals

State of the sensor	Indication LED for power supply and operation (green)	Indication LED for area determination (Orange)	Synchronization master output	Synchronization output	Malfunction output	Detection output 1 to 3
During start up	Blinking	ON		Tr = OFF (Hi) ^{*5}	Tr = OFF (Hi) ^{*5}	Tr = OFF (Hi) ^{*5}
During operation	ON	Detection ON No detection OFF		For 1 ms at the cycle of 50 ms Tr = ON (Low)	Tr = ON (Low)	Detection Tr = OFF (Hi) No detection Tr = ON (Low)
Malfunction	Blinking (Interval of 1 sec)			Tr = OFF (Hi)	Tr = OFF (Hi)	Tr = OFF (Hi)
Initialization of IP	Blinking 2 times after pushing and holding the IP initialization switch ↓ ON (Initialization processing of IP has been completed.) ↓ Blinking of the LED (green), the LED (orange) is OFF. (Restart of the sensor begins.) ↓ ON (Restart of the sensor has been completed.)		Output is always continued after the power supply for the sensor has been turned on. ^{*5}	During initialization of IP Tr = ON (Low) During restart of the sensor Tr = OFF (Hi) ^{*6}	During initialization of IP Tr = ON (Low) During restart of the sensor Tr = OFF (Hi) ^{*6}	Tr = OFF (Hi) ^{*6}

(Note)

^{*5} The state continues for about 5 sec after turning on the power supply

^{*6} The state continues during the period from completion of the initialization of IP to restart of the sensor

8. Heater function

This sensor is provided with an internal heater for preventing condensation. It is possible to enable the heater function to "on" or "off" using the dedicated application program. Heater function is "off" by default. When heater function is "on" the heater operates when the temperature inside the sensor is 0°C or below. When the temperature inside the sensor exceeds 10°C, operation of the heater is automatically stopped.

(Note) When using the heater function, it is recommended to use the sensor at the voltage of 24 V.

(If it is used at 12 V, the heating may not be sufficient due to lack of power to the heater.)

9. Setting of Ethernet

9.1 Default value of IP address

Default value of IP: 192.168.0.10

Port No.: 10940

9.2 Changing the IP address

IP address can be changed by using dedicated application program.

9.3 Initialization of IP address

Detach the protective M4 Seal screws at the bottom of the product, and press the IP initialization switch for 2 sec or more.

Release the switch once the green and orange LEDs blink to initiate sensor restart.

The protective M4 Seal screws can be replaced after initialization is successfully completed.

Bottom face of UXM

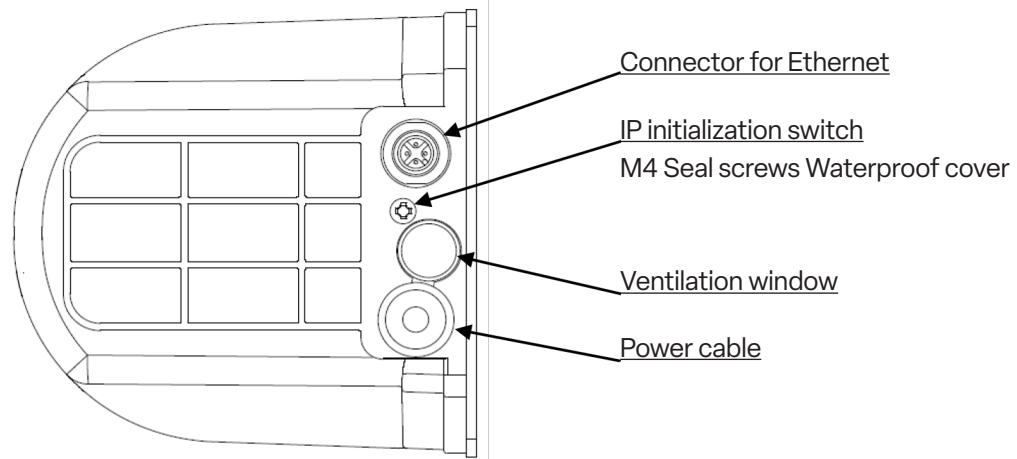



ISO14001 Certified
JQA-EM3873



ISO9001 Certified
JQA-1742

- Read instruction manual carefully before use.
- Products published in this brochure are intended to be used under specific conditions.
- For product related questions or technical issues, please contact our offices.



HOKUYO AUTOMATIC CO.,LTD.

Higobashi Union Building, 1-9-6 Edobori, Nishi-ku,
Osaka-shi, Osaka, 550-0002 Japan
TEL: +81-6-6441-2239 FAX: +81-6-6441-2204
URL: <http://www.hokuyo-aut.jp>
E-mail: info@hokuyo-aut.jp

● **EUROPE**
HOKUYO AUTOMATIC CO., LTD. Amsterdam Branch
Prof. J.H. Bavincklaan 2, 1183 AT Amstelveen, The Netherlands
TEL: +31-20-240-0110
E-mail: info@hokuyo-aut.jp

● **AMERICA**
Hokuyo Automatic USA Corporation
2019 Van Buren Ave. Suite A, Indian Trail, North Carolina 28079 U.S.A.
TEL: +1-704-882-3844
E-mail: sales@hokuyo-usa.com

● **KOREA**
HOKUYO KOREA CO., LTD.
104-211, 397 Seokcheon-Ro, Ojeong-Gu, Bucheon-City, Korea
TEL: +82-32-624-3194
E-mail: hokuyokorea@naver.com