

SPECIFICATIONS

OPTICAL DATA TRANSMISSION DEVICE
WITH LOGGING FUNCTION
CORRESPONDING TO SEMI E84-1000
CABLE 5m

DMG-GB1-Z07

Corresponding to SI unit

Symbol	Amended reason			Pages	Date	Corrector	Amended No.
Approved by	Checked by	Drawn by	Designed by	Title	Optical Data Transmission Device With Logging function DMG-GB1-Z07 Specifications		
			IGUCHI				

1. General

This is an optical data transmission device with 8 bits parallel I/O. This device provides with I/O data memorized function(Logging function) and so this function is very helpful to analyze when troubles such as interlocking etc. happened. Also, this device is compatible with standard models, DMS-HB1/GB1 series under the circumstances such as optical communication, input/output and installation and so it is easy to replace them at the current facilities.

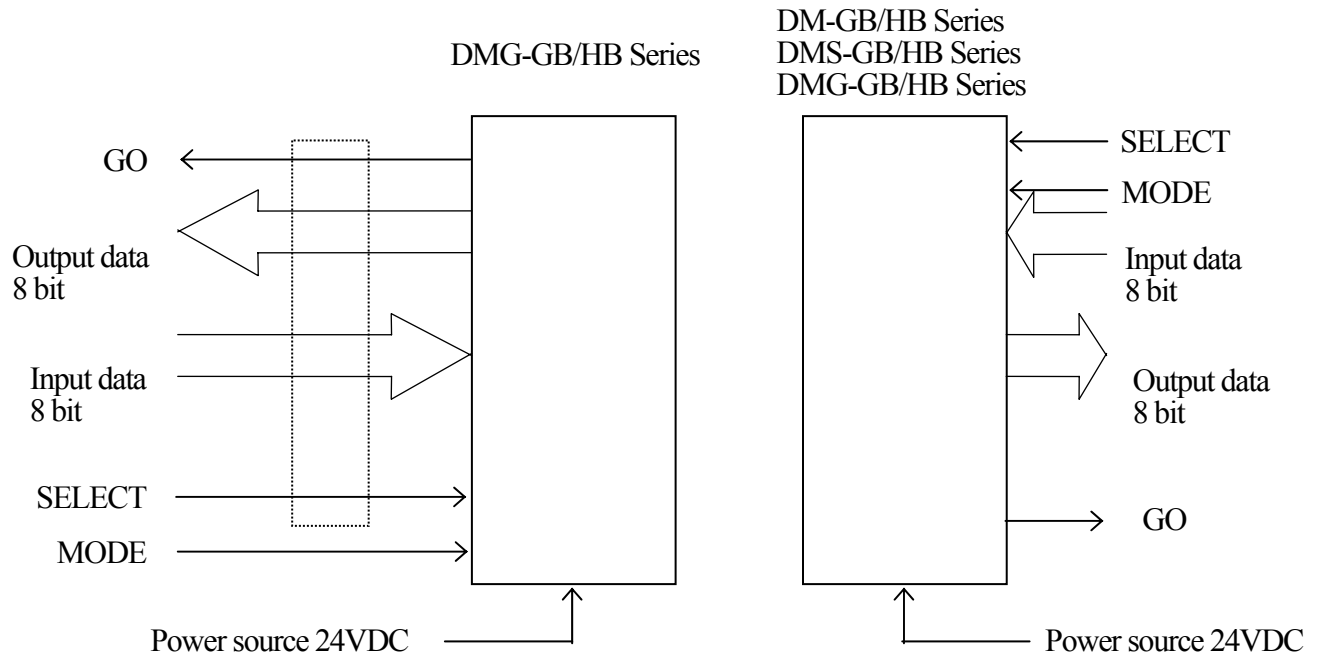

 Monitoring I/O data and logging data

* Refer to page 5 or later about specifications of logging functions etc.

2. Specifications

Model No.	DMG-GB1-Z07
Transmission distance	0 to 1m(With projection amount adjuster)
Directive angle	30° (Full angle)
Transmission directions	HEAD-ON
Transmission capacity (Input/Output)	8 bit/8 bit
Transmission method	Half-duplex two-way transmission
Transmission time	40msec
Modulation method	Pulse modulation
Verification method	Parity check
Power source	10 to 30VDC(24VDC is recommended)
Current consumption	100mA Max.
Ambient illuminance	4,000lux or less
Ambient temperature/humidity	-10 to 50 degrees C / 85%RH or less(Not dew-drops)
Vibration resistance	Double amplitude 1.5mm, 10 to 55Hz, Each 2 hour in X, Y and Z directions
Impact resistance	490m/s ² Each 10 time in X, Y and Z directions
Connection	D-sub 25 pins connector
Protective structure	IP64(Except for connector part)

Title

Optical Data Transmission Device With Logging function DMG-GB1-Z07 Specifications

Drawing No.

C-42-3484

2/7

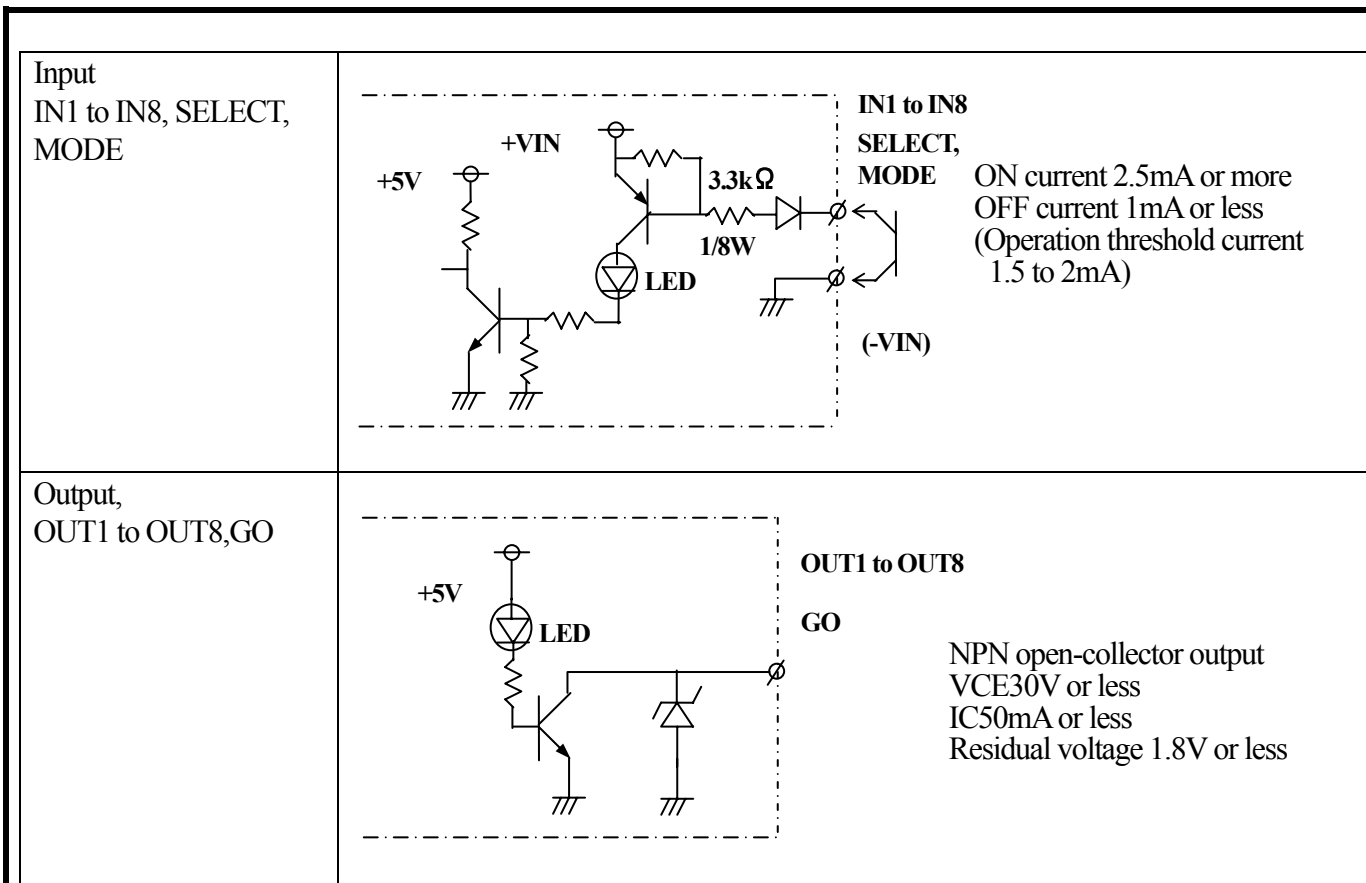

3. Logging data processing

(1) This device memorizes transmission/reception data, GO, SELECT and invariable time of reception data in non-volatile storage in all time by using changes of transmission/reception data, SELECT input and GO output as trigger. Note 1)

(2) Communication logging specifications

Data variable time	Max. 100 times ^{Note 2)}	
Memorizing data	Transmission/reception data : Each 8 bits, GO output, SELECT input	
Measuring unit of invariable time	0.05sec	
Measuring error of invariable time	+/- 0.05sec	
Measuring range of invariable time	Max. 1638.35sec(Approx. 27min.) ^{Note 3)}	
Memorizing media	Ferroelectric memory(512 byte)	
Memorizing cycle	Min. 20msec	
Memorizing life	Nos.	10 ¹⁰ times
	Years	10 years

Note 1) Transmission/reception data is monitored and memorized. It may be different with input/output data.

Note 2) In case that data variable Nos. exceed max. value, it is overwritten from older data.

Note 3) In case that measuring of invariable data for transmission/reception data exceeds max. value, it is Memorized as max. value.

4. Transmission characteristics

(1) Characteristics data

Unit(msec)

Items	Symbols	MIN	MAX
Input data holding time	tIH	30	-
Transmission time	tON, tOFF	13	40
Transmission starting delay time (Against optical axis coincidence)	tSD	30	110
Output holding time(Against SELECT A)	tOH1	50	90
Output holding time(Against SELECT B)	tOH2	-	5
Output holding time(Against light-interruption)	tOH3	50	90

(2) Characteristics measuring condition

*Mode : Side A – Reception stand-by mode, Side B – Transmission stand-by mode

*It was measured under input(side A) and output(side B).

(3) Measuring block diagram

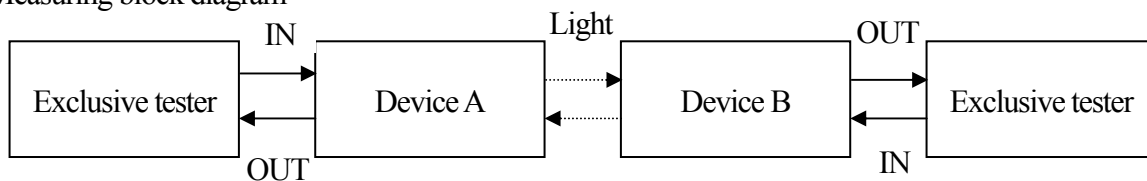

(4) Transmission timing

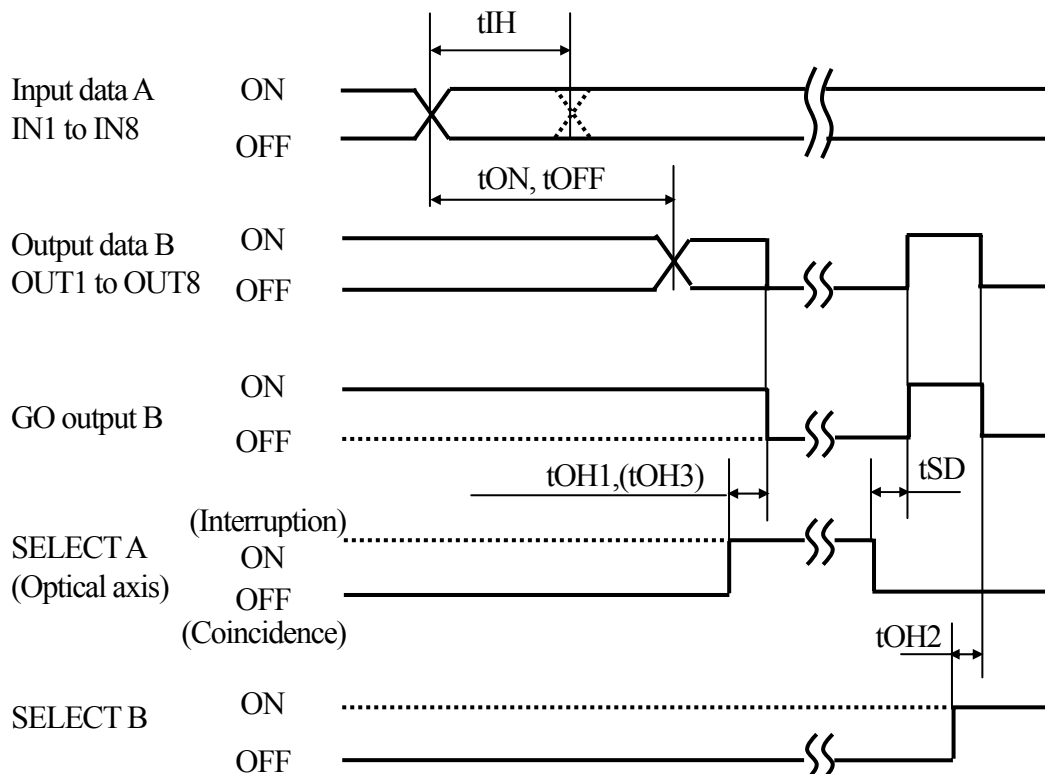

5. External wiring

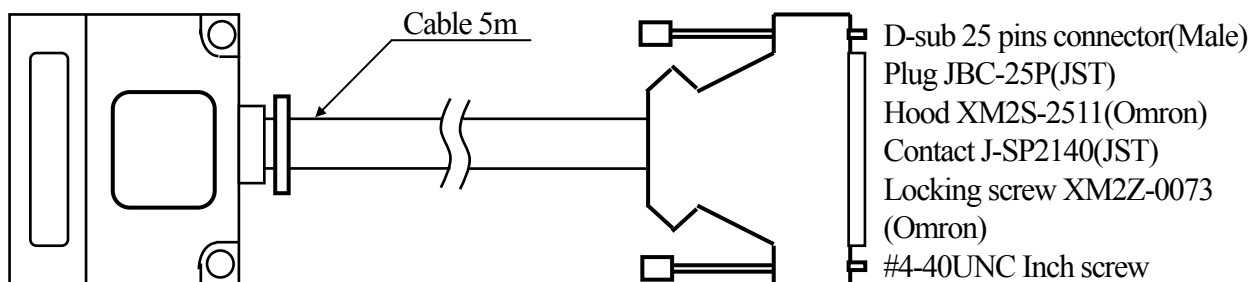

Colors	Pin No.	Functions
Brown	1	IN1
Red	2	IN2
Orange	3	IN3
Yellow	4	IN4
Green	5	IN5
Blue	6	IN6
Purple	7	IN7
Gray	8	IN8
White	10	SELECT
Pink	11	MODE
White/Black	12	GO

Colors	Pin No.	Functions
Brown/Black	14	OUT1
Red/Black	15	OUT2
Orange/Black	16	OUT3
Yellow/Black	17	OUT4
Green/Black	18	OUT5
Blue/Black	19	OUT6
Purple/Black	20	OUT7
Gray/Black	21	OUT8
Pink/Black	23	+VIN
---	22	+VIN
Pale blue/Black	24	-VIN
Pale blue	25	COM

* It is shorted between COM and -VIN, and 22 and 23 inside.

6. Function for each terminal

Terminals	Functions
IN1 to IN 8	Input data
OUT1 to OUT8	Output data
SELECT input	It is shorted to COM : Transmission/reception is stopped and logging data can't be read out. It is opened : Transmission/reception is operated and logging data can be read out.
MODE input(Note)	It is opened : Transmission standby mode It is shorted to COM : Reception standby mode
GO output	It is ON when normal data was received and OFF when light was interrupted or reception error.
COM	Common for input/output
+VIN	+24VDC(10 to 30V)
-VIN	0V
	Power source

Note) Make sure to set other one to reception standby mode.

7. Logging function of communication data

Logging function means to memorize both transmission/reception and variable time between Active equipment (A) and Passive Equipment(P) in a lump at all time when ordinary sequence will be made. Accordingly, the following sequence data(Time chart) can be memorized:-

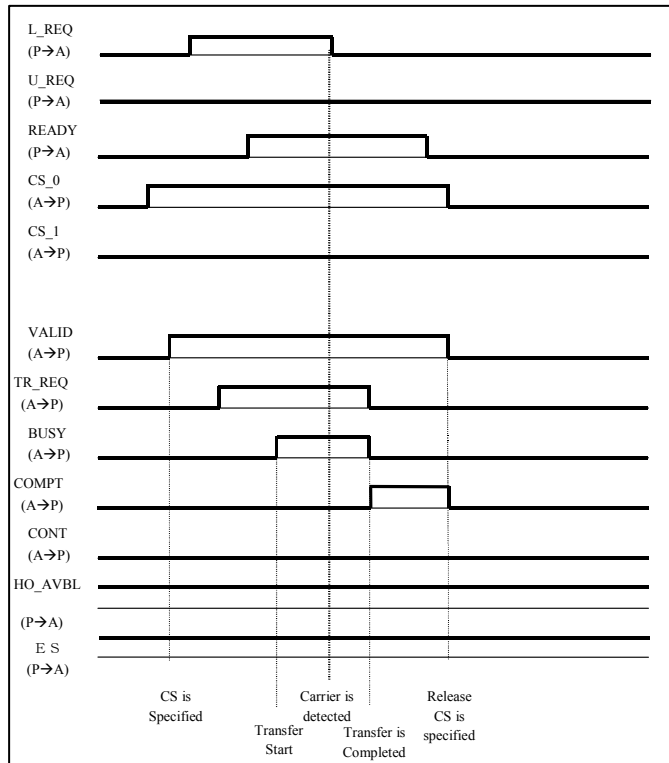

Single Time Diagram for Single Handoff(LOAD)

Title	Optical Data Transmission Device With Logging function DMG-GB1-Z07 Specifications	Drawing No.	C-42-3484	6/7
-------	---	-------------	-----------	-----

8. How to read out logging data

When some troubles such as interlocking etc. happened, you can read out memorized data with data transfer checker(Optical remote controller, option) and show them on PC with exclusive application software. It is easy to read out without removing cover because of reading out by optical communication. It is made by facing the head of data transfer checker(Optical remote controller) to transmission/reception part of DMG. However, when read out, make sure to be active status by releasing SELECT input(Opened or +VIN). (Refer to the specifications sheet of data transfer checker in details.)

Structure

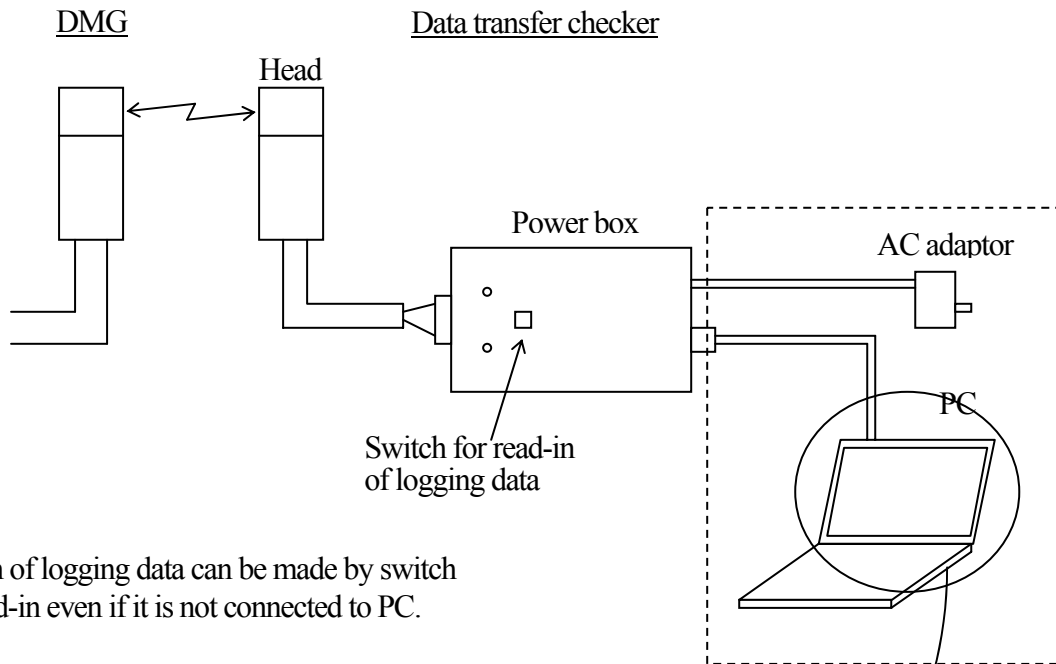

Read-in of logging data can be made by switch
For read-in even if it is not connected to PC.



Title

Optical Data Transmission Device With Logging
function DMG-GB1-Z07 Specifications

Drawing
No.

C-42-3484

7/7